

**Catalogo parti di ricambio**  
**Spare parts catalogue**  
**Catalogue pieces de rechange**  
**Ersatzteilliste**

**RD180-181 RD200-201**

**RD210-211 RD218**

**RD220-240 RD270-278**



**TAVOLA/TABLE**

---

1 BASAMENTO  
CRANKCASE  
CARTER MOTEUR  
KURBELGEHÄUSE

---

2 MANOVELLISMO  
CRANK MECHANISM  
EQUIPAGE MOBILE  
KURBELGETRIEBE

---

3 REGOLATORE GIRI  
GOVERNOR  
REGULATEUR DE TOURS  
REGLER

---

4 POMPA INIEZIONE E INIETTORE  
INJECTION PUMP AND INJECTOR  
5 POMPE A INJECTION-PORTE INJECTEUR  
6 EINSPRITZPUMPE UND EINSPRITZDÜSE

---

7 TESTA CILINDRO  
CYLINDER HEAD - CYLINDER  
CULASSE - ZYLINDER  
ZYLINDERKOPF - ZYLINDER

---

8 FILTRI ARIA  
AIR CLEANERS  
AIR CLEANERS  
LUFTFILTER

---

9 AVVIAMENTO ELETTRICO  
ELECTRICAL STARTING  
DEMARRAGE ELECTRIQUE  
ELEKTRISCHER ANLASSER

---

10 DISPOSITIVO ELETTRICOSTOP  
ELECTRO-MAGNET  
DISPOSITIF-ELECTROSTOP ARRET A DISTANCE  
ELEKTROSTOP

---

11 PRED. POMPA IDR. GR1 E GR2 SUL CARTER  
PRED. FOR HYDR. PUMP GR.1 AND GR.2  
PREDISPOSITION POMPE HYDR. GR1 ET GR2  
KREISELPUMPE ANBAUVORRICHTUNG GR1 GR2

---



**BASAMENTO - CRANKCASE  
CARTER MOTEUR - KURBELGEHÄUSE**

CATALOGO RICAMBI SPARE PARTS	
TAVOLA TABLE	1 1
DATA	06/2001

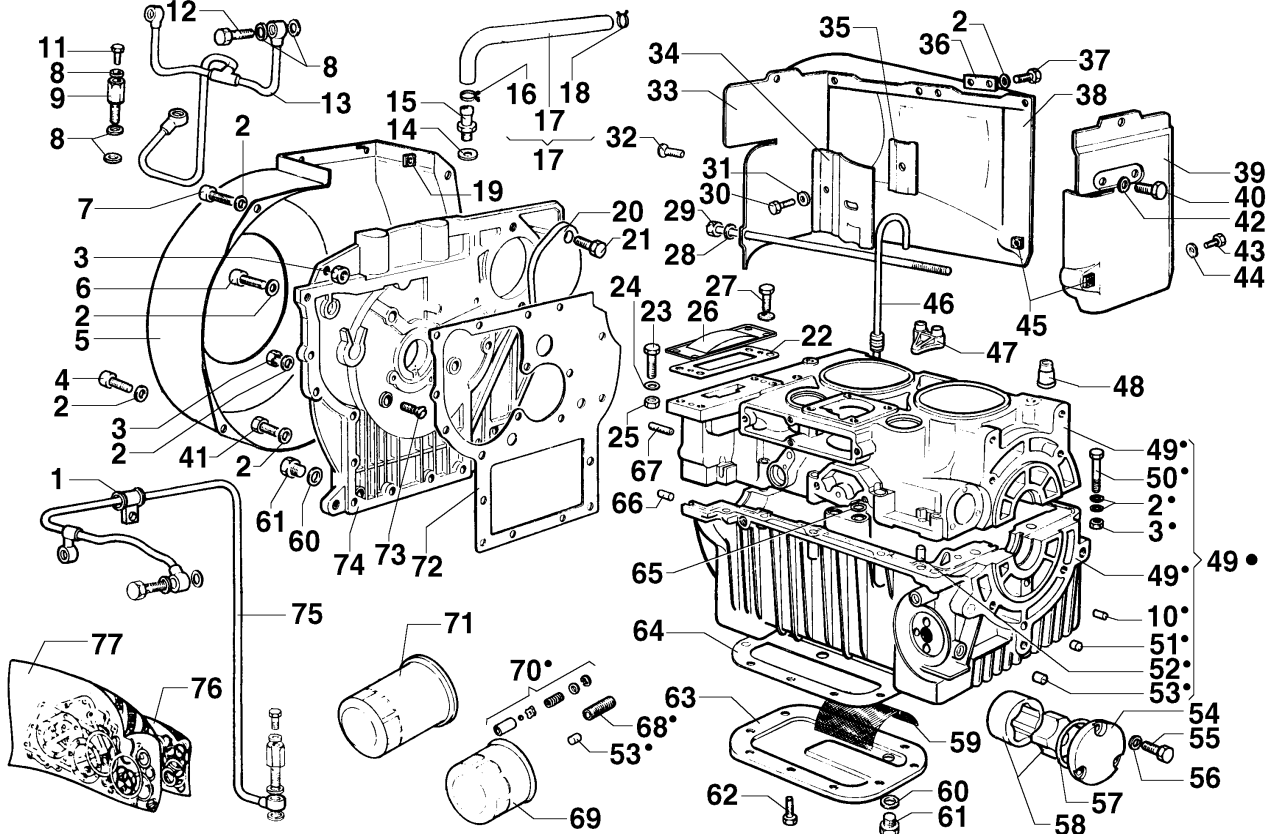

● ■ ▲ Particolari che compongono i kits / Parts included in the kit / Pièces comprises dans les kits / Bausatzteile

Nr. No.	OLD CODE	NEW CODE	RD180	RD200	RD210	RD218	RD220	RD240	RD270	RD278	DENOMINAZIONE - DESCRIPTION - DENOMINATION - BENENNUNG			
			RD181	RD201	RD211	Q.ty	Q.ty	Q.ty	Q.ty	Q.ty	Q.ty	Q.ty		
	C2508	00C25R0080	—	—	1	1	—	—	—	—	Short block	Short block	Short block	Short block
	C2524	00C25R0240	—	—	—	—	1	—	—	—	Blocco motore	Short block	Bloc moteur	Motorbloken
	C2525	00C25R0250	—	—	—	—	—	1	—	—	Blocco motore	Short block	Bloc moteur	Motorbloken
	C2526	00C25R0260	—	—	—	—	—	—	1	1	Blocco motore	Short block	Bloc moteur	Motorbloken
1	37545	00375R0450	1	1	1	1	—	—	—	—	Fascetta di sostegno tubo lubrif.	Clamp	Collier	Rohrschelle
2	77105	00771R0050	43	43	43	43	41	41	39	39	Rondella piana D.6,4x12,5 sp.1,6	Washer	Rondelle	Unterlegscheibe
3	32307	00323R0070	17	19	19	19	17	17	17	17	Dado M.6 H.6	Nut	Ecrou	Mutter
4	99225	0097300100	3	3	3	3	4	4	4	4	Vite vtcei M.6x16	Screw	Vis	Schraube
5	22838	00228R0380	1	1	1	1	—	—	—	—	Convogliatore aria (mpm)	Air conveyor	Coiffe ventil	Ventilatorhaube
	22852	00228R0520	—	—	—	—	1	1	1	1	Convogliatore aria	Air conveyor	Coiffe ventil	Ventilatorhaube
6	99314	0017600820	1	1	1	1	1	1	1	1	Vite vte M.6x35	Screw	Vis	Schraube
7	99207	0097300120	1	1	1	1	—	—	—	—	Vite vtcei M.6x20	Screw	Vis	Schraube
8	75402	00754R0020	5	18	18	18	14	14	14	14	Rondella rame D.8,2x12 sp.1	Washer	Rondelle	Unterlegscheibe
9	71642	00716R0420	1	1	1	1	1	1	1	1	Raccordo pressostato	Union	Raccord	Anschlußstück
10	88635	00886R0350	1	1	1	1	1	1	1	1	Tappo foro scarico olio corteco	Plug	Bouchon	Verschuß
11	99516	00995R0160	1	1	1	1	1	1	1	1	Vite vte M.8x1x10	Capscrew	Vis	Schraube
12	71673	00716R0730	2	2	2	2	2	2	2	2	Raccordo 8x1x25 (8.8) foro 3 mm.	Union	Raccord	Anschlußstück
13	94851	00948R0510	—	—	—	—	1	1	1	1	Tubo mandata olio testa	Pipe	Tuyau	Rohr
14	75407	00754R0070	1	1	1	1	1	1	1	1	Rondella rame D.12,2x18 sp.1	Washer	Rondelle	Unterlegscheibe
15	71733	00717R0330	1	1	1	1	1	1	1	1	Raccordo sfiato rd/2	Union	Raccord	Anschlußstück
16	37547	00375R0470	1	1	1	1	1	1	1	1	Fascetta	Clamp	Collier	Rohrschelle
17	94916	00949R0160	1	1	1	1	—	—	—	—	Tubo sfiato	Pipe	Tuyau	Rohr
	94915	00949R0150	—	—	—	—	1	1	1	1	Tubo sfiato	Pipe	Tuyau	Rohr
18	37551	00375R0510	1	1	1	1	1	1	1	1	Fascetta	Clamp	Collier	Rohrschelle
19	32665	00326R0650	3	3	3	3	—	—	—	—	Dado in gabbia M4	Nut	Ecrou	Mutter
	32634	00326R0340	—	—	—	—	3	3	3	3	Dado in gabbia M6	Nut	Ecrou	Mutter
20	23101	00231R0010	1	1	1	1	1	1	1	1	Coperchio sede motorino avviam.	Cover	Couvercle	Deckel
21	99318	0017800300	2	2	2	2	—	—	—	—	Vite vte M.10x20	Capscrew	Vis	Schraube
	99349	0017900370	—	—	—	—	2	2	2	2	Vite vte M.12x20	Screw	Vis	Schraube
22	45214	00452R0140	1	1	1	1	1	1	1	1	Guarnizione cop.sede pompa idr.	Gasket	Joint	Dichtung
23	99523	0017700070	2	2	2	2	2	2	2	2	Vite vte M.8x30	Screw	Vis	Schraube
24	77111	00771R0110	4	4	4	4	4	4	4	4	Rondella piana D.8,4x15 sp.1.5	Washer	Rondelle	Unterlegscheibe
25	32590	00325R0900	4	4	4	4	4	4	4	4	Dado speciale M.8 ch.12	Nut	Ecrou	Mutter
26	23441	00234R0410	1	1	1	1	1	1	1	1	Coperchio sede pompa idraulica	Cover	Couvercle	Deckel
27	99316	0017700040	2	2	2	2	2	2	2	2	Vite M.8x20	Capscrew	Vis	Schraube
28	77138	00771R0380	—	—	—	—	1	1	1	1	Rondella piana D.4,3x9 sp.0,8	Washer	Rondelle	Unterlegscheibe



**BASAMENTO - CRANKCASE  
CARTER MOTEUR - KURBELGEHÄUSE**

CATALOGO RICAMBI SPARE PARTS		
TAVOLA TABLE	1	2
DATA DATE	06/2001	

Nr. No.	OLD CODE	NEW CODE	RD180	RD200	RD210	RD218	RD220	RD240	RD270	RD278	DENOMINAZIONE - DESCRIPTION - DENOMINATION - BENENNUNG			
			RD181 Q.ty	RD201 Q.ty	RD211 Q.ty	Q.ty	Q.ty	Q.ty	Q.ty	Q.ty				
29	92621	00926R0210	—	—	—	—	1	1	1	1	Tirante cuffia-paratia	Tie rod	Entretoise	Zugstange
30	99362	00993R0620	1	1	1	1	1	1	1	1	Vite vte M.4x14	Capscrew	Vis	Schraube
31	77138	00771R0380	1	1	1	1	1	1	1	1	Rondella piana D.4,3x9 sp.0.8	Washer	Rondelle	Unterlegscheibe
32	99778	00997R0780	4	4	4	4	—	—	—	—	Vite vtc a croce M.4x10	Screw	Vis	Schraube
	99783	00997R0830	—	—	—	—	3	3	3	3	Vite vtc a croce M.6x16	Screw	Vis	Schraube
33	58856	00588R0560	1	1	1	1	—	—	—	—	Paratia lato volano	Conveyor	Défecteur	Luftbleibech
34	58860	00588R0600	1	1	1	1	—	—	—	—	Paratia esterna lato p.iniezione	Conveyor	Défecteur	Luftbleibech
	58864	00588R0640	—	—	—	—	1	1	1	1	Paratia esterna lato p.iniezione	Conveyor	Défecteur	Luftbleibech
35	58859	00588R0590	1	1	1	1	—	—	—	—	Paratia interna lato p.iniezione	Conveyor	Défecteur	Luftbleibech
	58870	00588R0700	—	—	—	—	1	1	1	1	Paratia interna lato p.iniezione	Conveyor	Défecteur	Luftbleibech
36	60830	00608R0300	1	1	1	1	1	1	1	1	Piastrina rinforzo cuffia	Plate	Arrêtoir	Sicherungsblech
37	99339	0017600320	6	6	6	6	6	6	6	6	Vite vte M.6x14	Capscrew	Vis	Schraube
38	29657	00296R0570	1	1	1	1	—	—	—	—	Cuffia cilindro (mpm)	Air baffle hood	Coiffe air	Kühlverkleidung
	29664	00296R0640	—	—	—	—	1	1	1	1	Cuffia cilindro	Air baffle hood	Coiffe air	Kühlverkleidung
39	58855	00588R0550	1	1	1	1	—	—	—	—	Paratia lato applicazione	Conveyor	Défecteur	Luftbleibech
	58863	00588R0630	—	—	—	—	1	1	1	1	Paratia lato applicazione	Conveyor	Défecteur	Luftbleibech
40	99337	0017700560	2	2	2	2	2	2	2	2	Vite vte M.8x18	Screw	Vis	Schraube
41	99305	0017600340	18	18	18	18	18	18	18	18	Vite vte M.6x25	Screw	Vis	Schraube
42	77109	00771R0090	2	2	2	2	2	2	2	2	Rondella piana D.8,4x17 sp.1,6	Washer	Rondelle	Unterlegscheibe
43	99778	00997R0780	1	1	1	1	—	—	—	—	Vite vtc a croce M.4x10	Screw	Vis	Schraube
44	77236	00772R0360	1	1	1	1	—	—	—	—	Rondella piana d.4x12.5 sp.1,6	Washer	Rondelle	Unterlegscheibe
45	32665	00326R0650	2	2	2	2	2	2	2	2	Dado in gabbia M4	Nut	Ecrou	Mutter
46	07653	00076R0820	1	1	1	1	1	1	1	1	Asta livello olio	Oil dipstick	Jauge huile	Meßstadi
47	15123	00151R0230	2	2	2	2	2	2	2	2	Cappellotto prigioniero	Cap	Capouchon	Schutzkappe
48	15124	00151R0240	4	4	4	4	4	4	4	4	Cappellotto	Cap	Capouchon	Schutzkappe
49	A2053	00A20R0530	1	1	1	1	1	1	—	—	Carter motore	Crankase	Carter moteur	Kurbelgehäuse
	A2055	00A20R0550	—	—	—	—	—	—	1	1	Carter motore	Crankase	Carter moteur	Kurbelgehäuse
50	99524	0017600160	10	10	10	10	9	9	9	9	Vite vte M.6x50	Screw	Vis	Schraube
51	88607	00886R0070	1	1	1	1	1	1	1	1	Tappo D.10	Plug	Bouchon	Verschuß
52	84124	0084001200	2	2	2	2	2	2	2	2	Spina cilindrica D.8x14	Taper pin	Goupille	Kegelstift
53	88652	00886R0520	2	2	2	2	2	2	2	2	Tappo conico alluminio d.12.65	Plug	Bouchon	Verschuß
54	23444	00234R0440	1	1	1	1	1	1	1	1	Coperchio pompa olio	Cover	Couvercle	Deckel
55	99307	0017550030	3	3	3	3	3	3	3	3	Vite vte M.5x16	Screw	Vis	Schraube
56	76705	00767R0050	3	3	3	3	3	3	3	3	Rondella ondulata d.5 din 137 "a"	Washer	Rondelle	Unterlegscheibe
57	57949	00579R0490	1	1	1	1	1	1	1	1	Anello OR D.41.00 sez.1,78	O-ring	Joint torique	O-Ring
58	A2384	00A23R0840	1	1	1	1	1	1	1	1	Pompa olio completa di perno	Oil pump	Pompe huile	Schmierölpumpe
59	73429	00734R0290	1	1	1	1	1	1	1	1	Rete filtro olio	Net	Grille	Netz
60	75401	00754R0010	2	2	2	2	2	2	2	2	Rondella allum.D.14,2x20 sp.1,5	Washer	Rondelle	Unterlegscheibe
61	89403	0089650050	2	2	2	2	2	2	2	2	Tappo filettato M.14x1,5 L.15	Threaded plug	Bouchon fileté	Verschußschraube
62	99310	0017600060	10	10	10	10	10	10	10	10	Vite vte M.6x20	Screw	Vis	Schraube
63	24856	00248R0560	1	1	1	1	1	1	1	1	Coppa olio in alluminio	Oil sump	Carter huile	Ölwanne
64	44886	00448R0860	1	1	1	1	1	1	1	1	Guarnizione coppa olio	Gasket	Joint	Dichtung
65	57939	00579R0390	8	8	8	8	8	8	8	8	Anello OR D.14.00 sez.1,78	O-ring	Joint torique	O-ring
66	88612	00886R0120	1	1	1	1	1	1	1	1	Tappo d.6 h.6 alluminio	Plug	Bouchon	Verschuß
67	85022	00850R0220	1	1	1	1	1	1	1	1	Spina elastica d.8.2x15	Taper pin	Goupille	Kegelstift
68	71715	00717R0150	1	1	1	1	1	1	1	1	Raccordo filtro olio	Union	Raccord	Anschlußstück
69	17524	0021752010	1	1	1	1	1	1	1	1	Cartuccia filtro olio	Filter Element	Cartouche Filtrante	Filtereinsatz
70	95645	00956R0450	1	1	1	1	1	1	1	1	Valvola by-pass completa	By-pass	Soupape by-pass	Ventil
71	17525	0021752020	1	1	1	1	1	1	1	1	Cartuccia olio maggiorata d. 76	Filter Element	Cartouche Filtrante	Filtereinsatz
	17531	0021752040	1	1	1	1	1	1	1	1	Cartuccia olio d. 96	Cartridge	Cartuche	Patrone
72	44891	00448R0910	2	2	2	2	2	2	2	2	Guarnizione cop.distribuz. 0.2mm	Gasket	Joint	Dichtung
	45161	00451R0610	1	1	1	1	1	1	1	1	Guarnizione cop.distribuz. 0.5mm	Gasket	Joint	Dichtung
	99362	00993R0620	—	—	—	—	1	1	1	1	Vite vte M.4x14	Capscrew	Vis	Schraube
73	99712	00997R0120	3	3	3	3	3	3	3	3	Vite vtspei M.6x20	Screw	Vis	Schraube
74	24029	00240R0290	1	1	1	1	—	—	—	—	Coperchio distribuzione	Cover	Couvercle	Deckel
	24078	00240R0780	—	—	—	—	1	1	1	1	Coperchio distribuzione	Cover	Couvercle	Deckel
75	94870	00948R0700	1	1	1	1	—	—	—	—	Tubo mandata olio testa	Pipe	Tuyau	Rohr
76	2931	0029310000	1	—	—	—	—	—	—	—	Serie guarnizioni smeriglio	Compl. gasket set	Joint	Dichtung
	2983	0029830000	—	1	—	—	—	—	—	—	Serie guarnizioni smeriglio	Compl. gasket set	Joint	Dichtung
	A2092	00A20R0920	—	—	1	1	—	—	—	—	Serie guarnizioni smeriglio	Compl. gasket set	Joint	Dichtung
	2400	0024000000	—	—	—	—	1	1	—	—	Serie guarnizioni smeriglio	Compl. gasket set	Joint	Dichtung
	2473	0024730000	—	—	—	—	—	—	1	1	Serie guarnizioni smeriglio	Compl. gasket set	Joint	Dichtung
77	2932	0029320000	1	—	—	—	—	—	—	—	Serie guarnizioni completa	Overhaul gasket set	Joint	Dichtung
	2984	0029840000	—	1	—	—	—	—	—	—	Serie guarnizioni completa	Overhaul gasket set	Joint	Dichtung
	A2093	00A20R0930	—	—	1	1	—	—	—	—	Serie guarnizioni completa	Overhaul gasket set	Joint	Dichtung
	2319	0023190000	—	—	—	—	1	1	—	—	Serie guarnizioni completa	Overhaul gasket set	Joint	Dichtung
	2472	0024720000	—	—	—	—	—	—	1	1	Serie guarnizioni completa	Overhaul gasket set	Joint	Dichtung



MANOVELLISMO - CRANK MECHANISM  
EQUIPAGE MOBILE - KURBELGETRIEBE

CATALOGO RICAMBI SPARE PARTS		
TAVOLA TABLE	2	1
DATA DATE	06/2001	

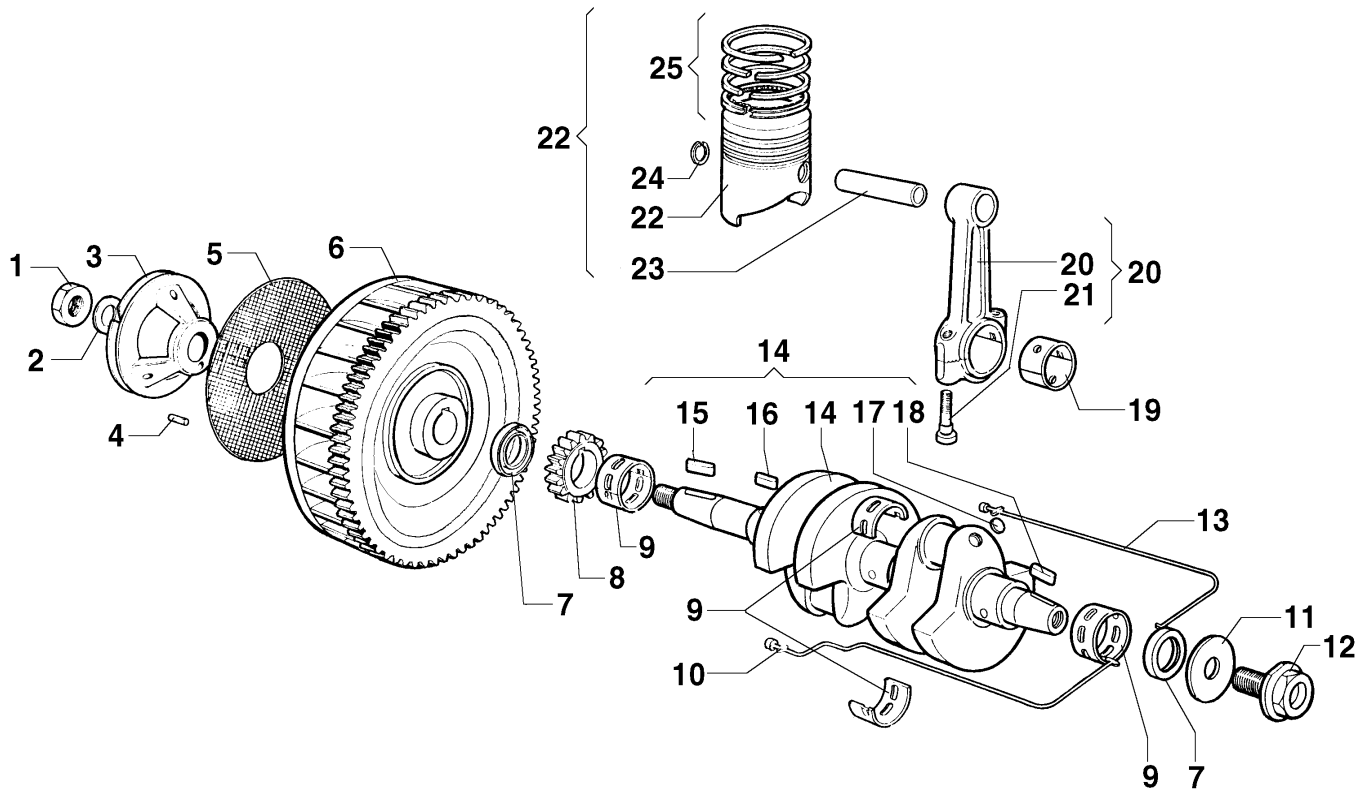

● ■ ▲ Particolari che compongono i kits / Parts included in the kit / Pièces comprises dans les kits / Bausatzteile

Nr. No.	OLD CODE	NEW CODE	RD180	RD200	RD210	RD218	RD220	RD240	RD270	RD278	DENOMINAZIONE - DESCRIPTION - DENOMINATION - BENENNING			
			RD181	RD201	RD211	Q.ty	Q.ty	Q.ty	Q.ty	Q.ty	Q.ty	Q.ty		
1	32314	00323R0140	1	1	1	1	1	1	1	1	Dado M.22x1,5 H.10	Nut	Ecrou	Mutter
2	77128	00771R0280	1	1	1	1	1	1	1	1	Rondella piana D.23x40 sp.4	Washer	Rondelle	Unterlegscheibe
3	69727	00697R0270	1	1	1	1	1	1	1	1	Puleggia avviamento	Pulley	Poulie	Riemenscheibe
4	85031	00850R0310	1	1	1	1	1	1	1	1	Spina elastica D.6x16	Taper pin	Goupille	Kegelstift
5	73470	00734R0700	1	1	1	1	1	1	1	1	Rete volano	Net	Grillage	Netz
6	0098813390	00988R0840	1	1	1	1	—	—	—	—	Volano con corona	Flyweel	Volant	Schwungrad
	98084	00980R0840	—	—	—	—	1	1	1	1	Volano con corona	Flyweel	Volant	Schwungrad
7	2312	0023120000	1	1	1	1	1	1	1	1	Serie anelli tenuta olio	Oli seal	Bague étanchéité	Dichtring
8	46852	00468R0520	1	1	1	1	1	1	1	1	Ingranaggio albero gomiti	Gear	Engrenage	Zahnrad
9	A2649	00A26R0490	3	3	3	3	3	3	3	3	Cuscinetto di banco STD	Bearing	Roulement	Lager
	A2650	00A26R0500	3	3	3	3	3	3	3	3	Cuscinetto di banco -0,25 mm	Bearing	Roulement	Lager
	A2651	00A26R0510	3	3	3	3	3	3	3	3	Cuscinetto di banco -0,50 mm	Bearing	Roulement	Lager
	A2654	00A26R0540	3	3	3	3	3	3	3	3	Cuscinetto di banco +1 mm	Main bearing	Coussinet de banc	Hauptlager
	A2652	00A26R0520	3	3	3	3	3	3	3	3	Cuscinetto di banco +1/-0.25 mm	Main bearing	Coussinet de banc	Hauptlager
	A2653	00A26R0530	3	3	3	3	3	3	3	3	Cuscinetto di banco +1/-0.50 mm	Main bearing	Coussinet de banc	Hauptlager
10	44962	00449R0620	1	1	1	1	1	1	1	1	Guarnizione (lato pompa iniez.)	Gasket	Joint	Dichtung
11	60801	00608R0010	1	1	1	1	1	1	1	1	Piastrina fermo bullone	Plate	Arrêtoir	Sicherungsblech
12	11601	00116R0010	1	1	1	1	1	1	1	1	Bullone lato flangiatura	Bolt	Boulon	Bolzen
13	44963	00449R0630	1	1	1	1	1	1	1	1	Guarnizione (lato asta liv.olio)	Gasket	Joint	Dichtung
14	2941	0029410000	1	1	1	1	—	—	—	—	Albero a gomiti	Crankshaft	Vilebrequin	Kurbelwelle
	2391	0023910000	—	—	—	—	1	1	1	1	Albero a gomiti	Crankshaft	Vilebrequin	Kurbelwelle
15	49819	00498R0190	1	1	1	1	1	1	1	1	Linguetta 6x6x25	Tab	Languette	Federkeil
16	49835	00498R0350	1	1	1	1	1	1	1	1	Linguetta 6x6x10	Key	Clavette	Keil
17	88644	00886R0440	4	4	4	4	4	4	4	4	Tappo a scodellino D.7	Plug	Bouchon	Verschuß
18	49819	00498R0190	1	1	1	1	—	—	—	—	Linguetta 6x6x25	Tab	Languette	Federkeil
	49810	0022100360	—	—	—	—	1	1	1	1	Linguetta 6x6x20	Key	Clavette	Keil
19	A2638	00A26R0380	2	2	2	2	2	2	2	2	Cuscinetto di biella STD	Bearing	Coussinet	Lager
	A2642	00A26R0420	2	2	2	2	2	2	2	2	Cuscinetto di biella -0.25 mm	Bearing	Coussinet	Lager
	A2643	00A26R0430	2	2	2	2	2	2	2	2	Cuscinetto di biella -0.50 mm	Bearing	Coussinet	Lager
20	10037	00100R0370	2	2	2	2	—	—	—	—	Biella completa	Connecting rod	Bielle	Peuelstange
	10023	00100R0230	—	—	—	—	2	2	2	2	Biella completa	Connecting rod	Bielle	Peuelstange
21	98960	00989R0600	4	4	4	4	—	—	—	—	Vite biella	Capscrew	Vis	Schraube
	98922	00989R0220	—	—	—	—	4	4	4	4	Vite biella	Screw	Vis	Schraube



**MANOVELLISMO - CRANK MECHANISM  
EQUIPAGE MOBILE - KURBELGETRIEBE**

CATALOGO RICAMBI SPARE PARTS		
TAVOLA TABLE	2	2
DATA DATE	06/2001	

Nr. No.	OLD CODE	NEW CODE	RD180	RD200	RD210	RD218	RD220	RD240	RD270	RD278	DENOMINAZIONE - DESCRIPTION - DENOMINATION - BENENNUNG			
			RD181 Q.ty	RD201 Q.ty	RD211 Q.ty	Q.ty	Q.ty	Q.ty	Q.ty	Q.ty				
22	A2012	00A20R0120	2	—	—	—	—	—	—	—	Pistone d.80 STD	Piston	Piston	Kolben
	A2013	00A20R0130	2	—	—	—	—	—	—	—	Pistone d.80.5	Piston	Piston	Kolben
	A2014	00A20R0140	2	—	—	—	—	—	—	—	Pistone d.81	Piston	Piston	Kolben
	A2293	00A22R0930	—	2	—	—	—	—	—	—	Pistone d.85 STD	Piston	Piston	Kolben
	A2147	00A21R0470	—	2	—	—	—	—	—	—	Pistone d.85.5	Piston	Piston	Kolben
	A2148	00A21R0480	—	2	—	—	—	—	—	—	Pistone d.86	Piston	Piston	Kolben
	A2063	00A20R0630	—	—	2	2	—	—	—	—	Pistone d.90 STD	Piston	Piston	Kolben
	A2064	00A20R0640	—	—	2	2	—	—	—	—	Pistone d.90.5	Piston	Piston	Kolben
	A2065	00A20R0650	—	—	2	2	—	—	—	—	Pistone d.91	Piston	Piston	Kolben
	A2407	00A24R0070	—	—	—	—	2	—	—	—	Pistone d.90 STD	Piston	Piston	Kolben
	A2408	00A24R0080	—	—	—	—	2	—	—	—	Pistone d.90.5	Piston	Piston	Kolben
	A2409	00A24R0090	—	—	—	—	2	—	—	—	Pistone d.91	Piston	Piston	Kolben
	2270	0022700000	—	—	—	—	—	2	—	—	Pistone d.92 STD	Piston	Piston	Kolben
	2271	0022710000	—	—	—	—	—	2	—	—	Pistone d.92.5	Piston	Piston	Kolben
	2272	0022720000	—	—	—	—	—	2	—	—	Pistone d.93	Piston	Piston	Kolben
	2492	0024920000	—	—	—	—	—	—	2	2	Pistone d.95 STD	Piston	Piston	Kolben
	2493	0024930000	—	—	—	—	—	—	2	2	Pistone d.95.5	Piston	Piston	Kolben
	2494	0024940000	—	—	—	—	—	—	2	2	Pistone d.96	Piston	Piston	Kolben
23	85412	00854R0120	2	—	—	—	—	—	—	—	Spinotto d.22 l.67.5	Piston pin	Axe du piston	Kolbenbolzen
	85417	00854R0170	—	2	2	2	—	—	—	—	Spinotto D.22x64 foro 11	Piston pin	Axe du piston	Kolbenbolzen
	85411	00854R0110	—	—	—	—	2	2	2	2	Spinotto d.25 l.74	Piston pin	Axe du piston	Kolbenbolzen
24	05011	0012410020	4	—	—	—	—	—	—	—	Anello seeger	Snap ring	Circlip	Sicherungsring
	05981	00059R0810	—	4	4	4	—	—	—	—	Anello fermo spinotto	Ring	Bague	Ring
	05006	0012400220	—	—	—	—	4	4	4	4	Anello seeger	Snap ring	Circlip	Sicherungsring
25	2340	0023400000	2	—	—	—	—	—	—	—	Serie segmenti d.80 STD (n.3)	Piston ring set	Série segments	Kolbenringsatz
	2341	0023410000	2	—	—	—	—	—	—	—	Serie segmenti d.80 +0.5 (n.3)	Piston ring set	Série segments	Kolbenringsatz
	2342	0023420000	2	—	—	—	—	—	—	—	Serie segmenti d.81 +1.0 (n.3)	Piston ring set	Série segments	Kolbenringsatz
	A2277	00A22R0770	—	2	—	—	—	—	—	—	Serie segmenti D.85 (2mm) STD	Piston rings	Segments	Kolben ring
	2992	0029920000	—	2	—	—	—	—	—	—	Serie segmenti d.85.5 (2mm)	Piston ring set	Série segments	Kolbenringsatz
	2993	0029930000	—	2	—	—	—	—	—	—	Serie segmenti d.86 (2mm)	Piston ring set	Série segments	Kolbenringsatz
	A2157	00A21R0570	—	—	—	—	2	—	—	—	Serie segmenti d.90 (n.3) STD	Piston ring set	Série segments	Kolbenringsatz
	A2158	00A21R0580	—	—	—	—	2	—	—	—	Serie segmenti d.90 +0.5 (n.3)	Piston ring set	Série segments	Kolbenringsatz
	A2159	00A21R0590	—	—	—	—	2	—	—	—	Serie segmenti d.90 +1.0 (n.3)	Piston ring set	Série segments	Kolbenringsatz
	2274	0022740000	—	—	—	—	—	2	—	—	Serie segmenti d.92 STD	Piston ring set	Série segments	Kolbenringsatz
	2275	0022750000	—	—	—	—	—	2	—	—	Serie segmenti d.92.5	Piston ring set	Série segments	Kolbenringsatz
	2276	0022760000	—	—	—	—	—	2	—	—	Serie segmenti d.93	Piston ring set	Série segments	Kolbenringsatz
	2495	0024950000	—	—	—	—	—	—	2	2	Serie segmenti d.95 STD (n.3)	Piston ring set	Série segments	Kolbenringsatz
	2496	0024960000	—	—	—	—	—	—	2	2	Serie segmenti d.95 +0.5 (n.3)	Piston ring set	Série segments	Kolbenringsatz
	2497	0024970000	—	—	—	—	—	—	2	2	Serie segmenti d.95 +1,0 (n.3)	Piston ring set	Série segments	Kolbenringsatz

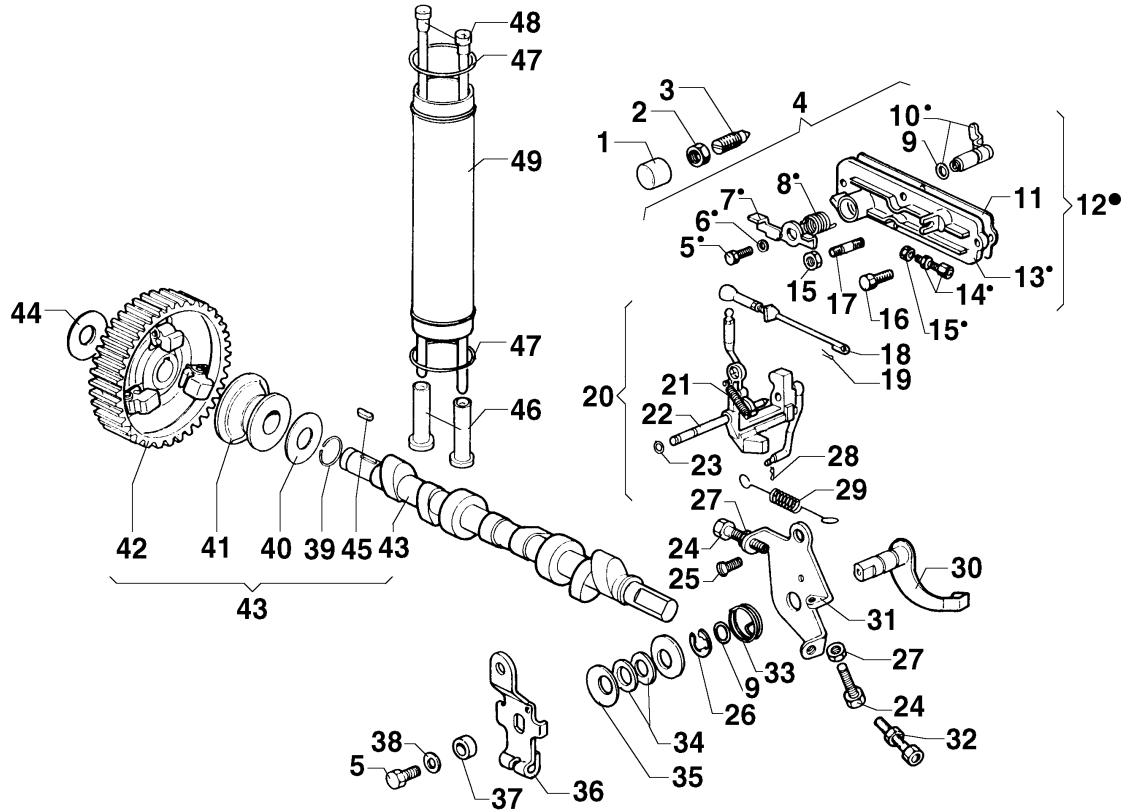

■ ● ▲ Particolari che compongono i kits / Parts included in the kit / Pièces comprises dans les kits / Bausatzteile

Nr. No.	OLD CODE	NEW CODE	RD180	RD200	RD210	RD218	RD220	RD240	RD270	RD278	DENOMINAZIONE - DESCRIPTION - DENOMINATION - BENENNUNG			
			RD181	RD201	RD211	Q.ty	Q.ty	Q.ty	Q.ty	Q.ty	Q.ty	Q.ty		
1	88651	00886R0510	1	1	1	1	1	1	1	1	Tappo dado supplemento	Plug	Bouchon	Verschluss
2	32574	00325R0740	1	1	1	1	1	1	1	1	Dado M.14x1 h8 ch19	Nut	Ecrou	Mutter
3	72209	00722R0090	1	1	1	1	1	1	1	1	Registro nafta suppl. meccanico	Adjusting screw	Vis réglage	Einstellschraube
4	2915	0029150000	1	1	1	1	1	1	1	1	Leva stop completa	Stop lever set	Levier compl.	Hebel
5	99312	0017600010	1	1	1	1	1	1	1	1	Vite vte M.6x10	Capscrew	Vis	Schraube
6	77105	00771R0050	1	1	1	1	1	1	1	1	Rondella piana D.6,4x12,5 sp.1,6	Washer	Rondelle	Unterlegscheibe
7	49331	00493R0310	1	1	1	1	1	1	1	1	Leva comando stop	Stop lever	Levier	Hebel
8	54725	00547R0250	1	1	1	1	1	1	1	1	Molla richiamo leva stop	Spring	Ressort	Feder
9	57901	00579R0010	2	2	2	2	2	2	2	2	Anello OR d.8.73 sez.1,78	O-ring	Joint torique	O-Ring
10	49329	00493R0290	1	1	1	1	1	1	1	1	Leva stop completa	Stop lever set	Levier compl.	Hebel
11	44855	00448R0550	1	1	1	1	1	1	1	1	Guarnizione coperchio tir.regol.	Gasket	Joint	Dichtung
12	23281	00232R0810	1	1	1	1	1	1	1	1	Coperchio tirante regolatore	Cover set	Couvercle	Deckel
13	23182	00231R0820	1	1	1	1	1	1	1	1	Coperchio tirante regolatore	Cover set	Couvercle	Deckel
14	72203	00722R0030	1	1	1	1	1	1	1	1	Registro tendi filo	Setscrew	Vis réglage	Einstellschraube
15	32307	00323R0070	2	2	2	2	2	2	2	2	Dado M.6 H.6	Nut	Ecrou	Mutter
16	99317	00993R0170	3	3	3	3	3	3	3	3	Vite vte M.6x18	Screw	Vis	Schraube
17	67707	00677R0070	1	1	1	1	1	1	1	1	Prigioniero M.6x18 r.6/3/15	Stud	Goujon	Stiftschraube
18	92638	00926R0380	1	1	1	1	1	1	1	1	Tirante comando p.iniez.completo	Tie rod	Entretoise	Zugstange
19	24402	00244R0020	1	1	1	1	1	1	1	1	Copiglia 2x10	Cotter pin	Goupille	Splint
20	49462	00494R0620	1	1	1	1	1	1	1	1	Leva regolatore	Lever	Levier	Hebel
21	55133	00551R0330	1	1	1	1	1	1	1	1	Molla regolatore	Governor spring	Ressort régulateur	Endregelfeder
22	60065	00600R0650	1	1	1	1	1	1	1	1	Perno fulcro leva regolatore	Shaft	Axe	Zapfen
23	57932	00579R0320	2	2	2	2	2	2	2	2	Anello OR D.2.90 sez.1,78	O-ring	Joint torique	O-ring
24	99305	0017600340	2	2	2	2	2	2	2	2	Vite vte M.6x25	Screw	Vis	Schraube
25	99710	00997R0100	1	1	1	1	1	1	1	1	Vite vtct M.8x12	Capscrew	Vis	Schraube
26	01601	00016R0010	1	1	1	1	1	1	1	1	Anello benzing D 8	Ring	Bague	Ring
27	32318	00323R0180	2	2	2	2	2	2	2	2	Dado	Nut	Ecrou	Mutter
28	55521	00555R0210	1	1	1	1	1	1	1	1	Molla di fermo su leva regolatore	Spring	Ressort	Feder
29	55124	00551R0240	1	1	1	1	1	1	1	1	Molla regolatore	Spring	Ressort	Feder
30	49477	00494R0770	1	1	1	1	1	1	1	1	Leva interna acceleratore	Throttle lever	Levier accèlérat.	Hebel
31	61203	00612R0030	1	1	1	1	1	1	1	1	Piastrina fine corsa leva accel.	Plate	Arrêtóir	Sicherungsblech
32	72214	00722R0140	1	1	1	—	1	1	1	—	Registro L.20	Setscrew	Vis réglage	Einstellschraube
33	54761	00547R0610	1	1	1	—	1	1	1	—	Molla acceleratore	Spring	Ressort	Feder
34	77704	00777R0040	—	—	—	2	—	—	—	2	Rondella ras.leva alzavalvola	Washer	Rondelle	Unterlegscheibe
35	74604	00746R0040	—	—	—	2	—	—	—	2	Rondella a tazza D.12.2x28 sp.2,	Washer	Rondelle	Unterlegscheibe
36	49476	00494R0760	1	1	1	1	1	1	1	1	Leva acceleratore	Throttle lever	Levier accèlérat.	Hebel



**REGOLATORE DI GIRI - GOVERNOR  
REGULATEUR DE TOURS - REGLER**

CATALOGO RICAMBI SPARE PARTS		
TAVOLA TABLE	<b>3</b>	<b>2</b>
DATA DATE	06/2001	

Nr. No.	OLD CODE	NEW CODE	RD180	RD200	RD210	RD218	RD220	RD240	RD270	RD278	DENOMINAZIONE - DESCRIPTION - DENOMINATION - BENENNUNG			
			RD181 Q.ty	RD201 Q.ty	RD211 Q.ty	Q.ty	Q.ty	Q.ty	Q.ty	Q.ty				
37	77217	00772R0170	1	1	1	1	1	1	1	1	Rondella piana d.12.5x18 sp.3	Washer	Rondelle	Unterlegscheibe
38	77151	00771R0510	1	1	1	1	3	3	3	3	Rondella piana D.6,6x18 sp.2	Washer	Rondelle	Unterlegscheibe
39	05985	00059R0850	1	1	1	1	1	1	1	1	Anello arresto	Ring	Bague	Ring
40	77778	00777R0780	1	1	1	1	1	1	1	1	Rondella rasamento	Washer	Rondelle	Unterlegscheibe
41	62122	00621R0220	1	1	1	1	1	1	1	1	Piattello regolatore	Retainer	Coupelle	Federteller
42	46978	00469R0780	1	1	1	1	1	1	1	1	Ingranaggio albero a camme	Gear	Engrenage	Zahnrad
43	A2383	00A23R0830	1	1	—	—	—	—	—	—	Albero a camme	Camshaft	Arbre à cames	Nockenwelle
	A2379	00A23R0790	—	—	1	—	1	1	1	—	Albero a camme	Camshaft	Arbre à cames	Nockenwelle
	A2381	00A23R0810	—	—	—	1	—	—	—	1	Albero a camme	Camshaft	Arbre à cames	Nockenwelle
44	77733	00777R0330	1	1	1	1	1	1	1	1	Rondella rasamento 0,3 mm	Washer	Rondelle	Unterlegscheibe
45	49836	00498R0360	1	1	1	1	1	1	1	1	Linguetta 4x4x12	Tab	Languette	Federkeil
46	70813	00708R0130	4	4	4	4	4	4	4	4	Punteria	Tappet	Poussoir	Stößel
47	57946	00579R0460	4	4	4	4	4	4	4	4	Anello OR D.37.47 sez.3,00	O-ring	Joint torique	O-ring
48	07158	00071R0580	4	4	4	4	—	—	—	—	Asta bilancieri	Push rod	Tige poussoir	Stößstange
	07165	00071R0650	—	—	—	—	4	4	4	4	Asta bilancieri	Push rod	Tige poussoir	Stößstange
49	94021	00940R0210	2	2	2	2	—	—	—	—	Tube custodia aste bilancieri	Tube	Tuyau	Rohr
	94006	00940R0060	—	—	—	—	2	2	2	2	Tube custodia aste bilancieri	Tube	Tuyau	Rohr



**POMPA INIEZIONE E INIETTORE - INJECTION PUMP AND INJECTOR**  
**POMPE A INJECTION-ORTE INJECTEUR - EINSPRITZPUMPE UND EINSPRITZDÜSE**

CATALOGO RICAMBI SPARE PARTS		
TAVOLA TABLE	4	1
DATA DATE	06/2001	

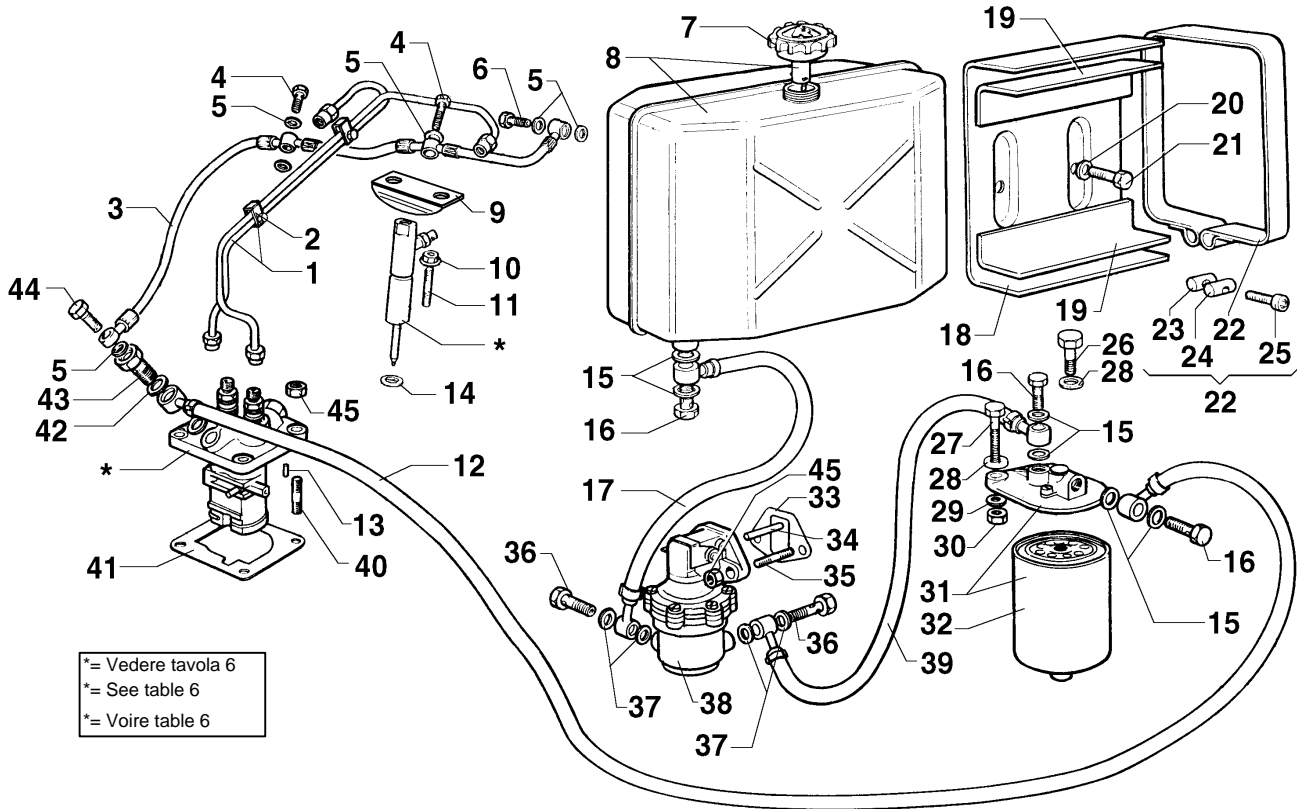

\*= Vedere tavola 6  
 \*= See table 6  
 \*= Voir table 6

● ■ ▲ Particolari che compongono i kits / Parts included in the kit / Pièces comprises dans les kits / Bausatzteile

Nr. No.	OLD CODE	NEW CODE	RD180	RD200	RD210	RD218	RD220	RD240	RD270	RD278	DENOMINAZIONE - DESCRIPTION - DENOMINATION - BENENNUNG			
			RD181	RD201	RD211	Q.ty	Q.ty	Q.ty	Q.ty	Q.ty	Q.ty	Q.ty		
1	94458	00944R0580	—	—	—	—	1	1	1	1	Tubi iniezione (foro d.2)	Injection pipe	Tube injection	Rohr
2	37544	00375R0440	1	1	1	1	2	2	2	2	Morsetto	Terminal connector	Bride	Anschlussklemme
3	93788	00937R0880	—	—	—	—	1	1	1	1	Tubo disareazione	Pipe	Tuyau	Rohr
4	71670	0019010290	2	2	2	2	2	2	2	2	Raccordo m.8x1 l.16	Union	Raccord	Anschlußstück
5	75402	00754R0020	2	2	2	2	8	8	8	8	Rondella rame D.8,2x12 sp.1	Washer	Rondelle	Unterlegscheibe
6	71672	00716R0720	1	1	1	1	1	1	1	1	Raccordo 8x1x20 (8.8)	Union	Raccord	Anschlußstück
7	89822	00898R0220	1	1	1	1	1	1	1	1	Tappo serbatoio M.36x2	Plug	Bouchon	Verschuß
8	A2049	00A20R0490	—	—	—	—	1	1	1	1	Serbatoio h.170 unificato compl.	Tank	Réservoir	Kraftstoffbehälter
9	85872	00858R0720	—	—	—	—	2	2	2	2	Staffa inietttore	Brace	Etrier	Bügel
10	32378	00323R0780	—	—	—	—	4	4	4	4	Dado autobloccante M.8 H.7,9	Nut	Ecrou	Mutter
11	67723	00677R0230	—	—	—	—	4	4	4	4	Prigioniero M.8x75 r20/53/22	Stud	Goujon	Stiftschraube
12	93571	00935R0710	—	—	—	—	1	1	1	1	Tubo nafta da filtro a p.in.	Pipe	Tuyau	Rohr
13	84116	00841R0160	1	1	1	1	1	1	1	1	Spina cilindrica d 4x12	Taper pin	Goupille cyl.	Kegelstift
14	75406	00754R0060	—	—	—	—	4	4	4	4	Rondella rame d.9x21.5 sp.0,5	Washer	Rondelle	Unterlegscheibe
15	75401	00754R0010	2	2	2	2	6	6	6	6	Rondella allum.D.14,2x20 sp.1,5	Washer	Rondelle	Unterlegscheibe
16	71615	0019010320	1	1	1	1	3	3	3	3	Raccordo 14x1.5x27	Union	Raccord	Anschlußstück
17	93569	00935R0690	—	—	—	—	1	1	1	1	Tubo nafta da serbat.a pompa ac	Pipe	Tuyau	Rohr
18	87526	00875R0260	—	—	—	—	1	1	1	1	Supporto serbatoio	Support	Support	Lager
19	37908	00379R0080	—	—	—	—	2	2	2	2	Feltro serbatoio	Felt gasket	Feutre	Filz
20	77109	00771R0090	—	—	—	—	2	2	2	2	Rondella piana D.8,4x17 sp.1,6	Washer	Rondelle	Unterlegscheibe
21	99321	0017701270	—	—	—	—	2	2	2	2	Vite vte M.8x14	Screw	Vis	Schraube
22	2318	0023180000	—	—	—	—	2	2	2	2	Fascette serbatoio complete	Clamp	Collier	Rohrschelle
23	79702	00797R0020	—	—	—	—	2	2	2	2	Rullo d.12x25 foro m.6	Roller	Galet	Rolle
24	79701	00797R0010	—	—	—	—	2	2	2	2	Rullo d.12x25 foro d.6.5	Roller	Galet	Rolle
25	99272	00992R0720	—	—	—	—	2	2	2	2	Vite vtcei M.6x45	Screw	Vis	Schraube
26	99511	0017600150	—	—	—	—	1	1	1	1	Vite vte M.6x45	Screw	Vis	Schraube
27	99562	00995R0620	—	—	—	—	1	1	1	1	Vite vte M.6x60	Screw	Vis	Schraube
28	77151	00771R0510	—	—	—	—	2	2	2	2	Rondella piana D.6,6x18 sp.2	Washer	Rondelle	Unterlegscheibe
29	77105	00771R0050	—	—	—	—	2	2	2	2	Rondella piana D.6,4x12,5 sp.1,6	Washer	Rondelle	Unterlegscheibe
30	32307	00323R0070	—	—	—	—	2	2	2	2	Dado M.6 H.6	Nut	Ecrou	Mutter
31	39116	00391R0160	—	—	—	—	1	1	1	1	Filtro nafta esterno	Fuel filter	Filter combustible	Brennstofffilter
32	17519	0021751970	—	—	—	—	1	1	1	1	Cartuccia filtro nafta	Cartridge	Cartouche	Patrone
33	45075	00450R0750	2	2	2	2	2	2	2	2	Guarnizione p.a.c. 0,2 mm	Gasket	Joint	Dichtung
	45169	00451R0690	3	3	3	3	3	3	3	3	Guarnizione pompa a.c. 0,5 mm	Gasket	Joint	Dichtung
34	70405	00704R0050	1	1	1	1	1	1	1	1	Puntalino pompa a.c.	Drive rod	Poussoir	Betätigungsstange
35	67602	00676R0020	2	2	2	2	2	2	2	2	Prigioniero M.8x20	Stud	Goujon	Stiftschraube



**POMPA INIEZIONE E INIETTORE - INJECTION PUMP AND INJECTOR**  
**POMPE A INJECTION-ORTE INJECTEUR - EINSPRITZPUMPE UND EINSPRITZDÜSE**

CATALOGO RICAMBI  
 SPARE PARTS  
 TAVOLA  
 TABLE **4 2**  
 DATA  
 DATE **06/2001**

Nr. No.	OLD CODE	NEW CODE	RD180	RD200	RD210	RD218	RD220	RD240	RD270	RD278	DENOMINAZIONE - DESCRIPTION - DENOMINATION - BENENNUNG			
			RD181 Q.ty	RD201 Q.ty	RD211 Q.ty	Q.ty	Q.ty	Q.ty	Q.ty	Q.ty				
36	71625	0019010300	2	2	2	2	2	2	2	2	Raccordo 10x1x23	Union	Raccord	Anschlußstück
37	75409	00754R0090	4	4	4	4	4	4	4	4	Rondella D.10,2x16,5 sp.1,5	Washer	Rondelle	Unterlegscheibe
38	65212	00652R0120	1	1	1	1	1	1	1	1	Pompa a.c.	Fuel feeding pump	Pompe comb.	Kraftstoffpumpe
39	93570	00935R0700	—	—	—	—	1	1	1	1	Tube nafta occhielli d.10-14	Pipe	Tuyau	Rohr
40	67670	00676R0700	4	4	4	4	4	4	4	4	Prigioniero M.8x20	Stud	Goujon	Stiftschraube
41	44772	00447R0720	2	2	2	2	2	2	2	2	Guarnizione pompa iniezione 0.1mm	Gasket	Joint	Dichtung
	44841	00448R0410	1	1	1	1	1	1	1	1	Guarnizione pompa iniezione 0.2mm	Gasket	Joint	Dichtung
	44872	00448R0720	2	2	2	2	2	2	2	2	Guarnizione pompa iniezione 0.3mm	Gasket	Joint	Dichtung
42	75408	00754R0080	2	2	2	2	2	2	2	2	Rondella rame D.12,2x16 sp.1,5	Washer	Rondelle	Unterlegscheibe
43	71717	0019010120	1	1	1	1	1	1	1	1	Raccordo completo disaereazione	Union	Raccord	Anschlußstück
44	71729	00717R0290	1	1	1	1	1	1	1	1	Raccordo m.8x1x16 foro 0.9	Union	Raccord	Anschlußstück
45	32303	00323R0030	6	6	6	6	6	6	6	6	Dado M.8 H.8	Nut	Ecrou	Mutter

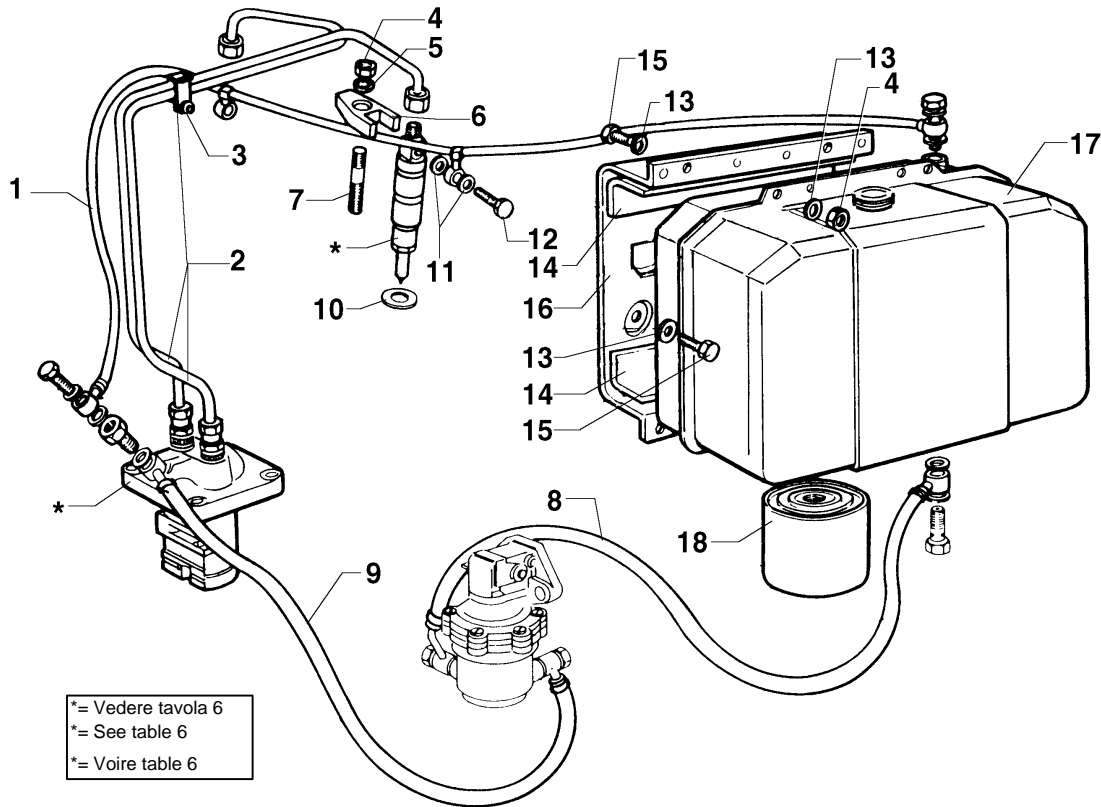

\*= Vedere tavola 6  
 \*= See table 6  
 \*= Voir table 6

Nr. No.	OLD CODE	NEW CODE	RD180	RD200	RD210	RD218	RD220	RD240	RD270	RD278	DENOMINAZIONE - DESCRIPTION - DENOMINATION - BENENNUNG			
			RD181	RD201	RD211	Q.ty	Q.ty	Q.ty	Q.ty	Q.ty	Q.ty	Q.ty		
1	93638	00936R0380	1	1	1	1	—	—	—	—	Tubo disareazione	Pipe	Tuyau	Rohr
2	94434	00944R0340	1	1	1	—	—	—	—	—	Tubi iniezione	Injection pipe	Tube injection	Rohr
	94462	00944R0620	—	—	—	1	—	—	—	—	Tubi iniezione (foro d.1.2)	Injection pipe	Tube injection	Rohr
3	37544	00375R0440	1	1	1	1	—	—	—	—	Morsetto	Terminal connector	Bride	Anschlussklemme
4	32303	00323R0030	6	6	6	6	—	—	—	—	Dado M.8 H.8	Nut	Ecrou	Mutter
5	77197	00771R0970	2	2	2	2	—	—	—	—	Rondella D.8,4x15 sp.7,5	Washer	Rondelle	Unterlegscheibe
6	85894	00858R0940	2	2	2	2	—	—	—	—	Staffa iniettore	Brace	Etrier	Bügel
7	67688	00676R0880	2	2	2	2	—	—	—	—	Prigioniero M.8x32 r.15/12/20	Stud	Goujon	Stiftschraube
8	93692	00936R0920	1	1	1	1	—	—	—	—	Tubo nafta da serbat.a pompa ac	Pipe	Tuyau	Rohr
9	93603	00936R0030	1	1	1	1	—	—	—	—	Tubo nafta pompa ac pompa iniez.	Pipe	Tuyau	Rohr
10	75435	00754R0350	2	2	2	2	—	—	—	—	Rondella rame D.7,25x21 sp.1	Washer	Rondelle	Unterlegscheibe
11	75439	00754R0390	4	4	4	4	—	—	—	—	Rondella rame	Washer	Rondelle	Unterlegscheibe
12	71728	00717R0280	2	2	2	2	—	—	—	—	Raccordo	Union	Raccord	Anschlußstück
13	77111	00771R0110	10	10	10	10	—	—	—	—	Rondella piana D.8,4x15 sp.1,5	Washer	Rondelle	Unterlegscheibe
14	37914	00379R0140	2	2	2	2	—	—	—	—	Feltro serbatoio	Felt gasket	Feutre	Filz
15	99337	0017700560	6	6	6	6	—	—	—	—	Vite vte M.8x18	Screw	Vis	Schraube
16	87789	00877R0890	1	1	1	1	—	—	—	—	Supporto serbatoio	Fuel tank bracket	Support réservoir	Kraftstoffbehälterlager
17	A2048	00A20R0480	1	1	1	1	—	—	—	—	Serbatoio nafta con sede filtro	Fuel tank	Réservoir	Kraftstoffbehälter
18	17523	0021752000	1	1	1	1	—	—	—	—	Cartuccia nafta	Filter element	Cartouche filtrante	Filtereinsatz



**POMPA INIEZIONE E INIETTORE - INJECTION PUMP AND INJECTOR**  
**POMPE A INJECTION-ORTE INJECTEUR - EINSPRITZPUMPE UND EINSPRITZDÜSE**

CATALOGO RICAMBI SPARE PARTS		
TAVOLA TABLE	<b>6</b>	<b>1</b>
DATA DATE	06/2001	

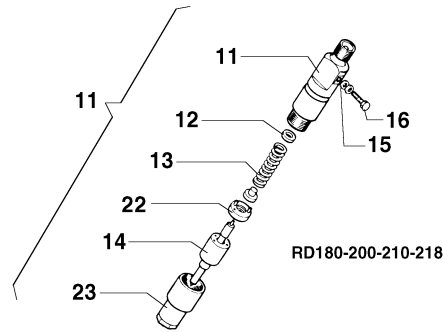
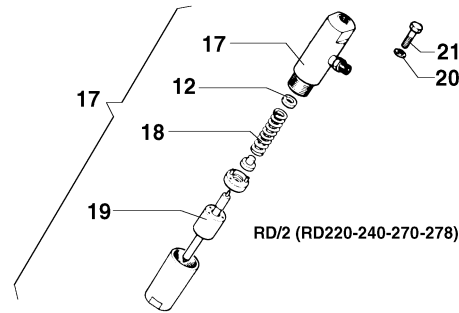
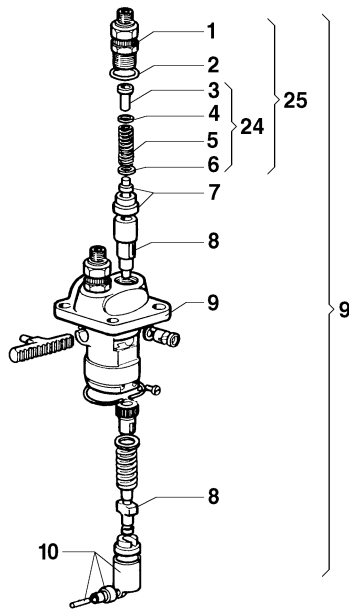

Nr. No.	OLD CODE	NEW CODE	RD180	RD200	RD210	RD218	RD220	RD240	RD270	RD278	DENOMINAZIONE - DESCRIPTION - DENOMINATION - BENENNUNG			
			Q.ty	Q.ty	Q.ty	Q.ty	Q.ty	Q.ty	Q.ty	Q.ty	Q.ty			
1	71705	00717R0050	2	2	2	2	2	2	2	2	Raccordo	Union	Raccord	Anschlußstück
2	57921	00579R0210	2	2	2	2	2	2	2	2	Anello OR d.15.60 sez.1,78	O-ring	Joint torique	O-Ring
3	71706	0074700030	2	2	2	2	2	2	2	2	Riempitore	Union	Raccord	Anschlußstück
4	83727	00837R0270	2	2	2	2	2	2	2	2	Rondella pompa iniezione	Shim	Cale	Unterlegscheibe
5	54045	00540R0450	2	2	2	2	2	2	2	2	Molla pompa iniezione	Spring	Ressort	Feder
6	75417	00754R0170	2	2	2	2	2	2	2	2	Rondella pompa iniezione	Washer	Rondelle	Unterlegscheibe
7	95631	00956R0310	2	2	2	2	—	—	—	—	Valvolina STANADYNE _K60	Valve	Soupape	Ventil
	95651	00956R0510	2	2	2	2	—	—	—	—	Valvola NEW DIESEL	Valve	Soupape	Ventil
	95627	0096720120	—	—	—	—	2	2	2	2	Valvolina STANADYNE _K70	Valve	Soupape	Ventil
	95625	00956R0250	—	—	—	—	2	2	2	—	Valvolina BOSCH _K70	Valve	Soupape	Ventil
8	66020	00660R0200	2	2	2	2	—	—	—	—	Pompante STANADYNE _K60	Pumping element	Element pompe	Pumpenelement
	66021	00660R0210	2	2	2	2	—	—	—	—	Pompante BOSCH _K60	Pumping element	Element pompe	Pumpenelement
	66013	00660R0130	—	—	—	—	2	2	2	—	Pompante BOSCH _K70	Pumping element	Element pompe	Pumpenelement
	66017	00660R0170	—	—	—	—	2	2	2	—	Pompante STANADYNE _K70	Pumping element	Element pompe	Pumpenelement
	66018	00660R0180	—	—	—	—	—	—	—	2	Pompante STANADYNE _K80	Pumping element	Element pompe	Pumpenelement
9	65621	00656R0210	1	1	1	1	—	—	—	—	Pompa iniezione STANADYNE 2k60	Injection pump	Pompe injection	Einspritzpumpe
	65648	00656R0480	1	1	1	1	—	—	—	—	Pompa iniezione BOSCH 2k60	Injection pump	Pompe injection	Einspritzpumpe
	65617	00656R0170	—	—	—	—	1	1	1	—	Pompa iniezione STANADYNE 2k70	Injection pump	Pompe injection	Einspritzpumpe
	65619	00656R0190	—	—	—	—	1	1	1	—	Pompa iniezione BOSCH 2k70	Injection pump	Pompe injection	Einspritzpumpe
	65668	00656R0680	—	—	—	—	—	—	—	1	Pompa iniezione STANADYNE 2k80	Injection pump	Pompe injection	Einspritzpumpe
10	70808	00708R0080	2	2	2	2	2	2	2	2	Punteria pompa iniezione	Tappet	Poussoir	Stößel
11	64438	00644R0380	2	2	2	2	—	—	—	—	Iniettore completo STANADYNE	Injector	Injecteur compl.	Einspritzdüse
	64430	00644R0300	2	2	2	2	—	—	—	—	Iniettore completo BOSCH	Injector	Injecteur compl.	Einspritzdüse
12	83730	00837R0300	2	2	2	2	2	2	2	2	Rondella taratura 0,1 mm	Shim	Cale	Unterlegscheibe
	83735	00837R0350	2	2	2	2	2	2	2	2	Spessore di taratura 1 mm	Shim	Cale	Unterlegscheibe
13	54079	00540R0790	2	2	2	2	—	—	—	—	Molla	Spring	Ressort	Feder
14	64437	00644R0370	2	2	2	2	—	—	—	—	Polverizzatore STANADYNE	Nozzle	Injecteur	Düse
	64436	00644R0360	2	2	2	2	—	—	—	—	Polverizzatore BOSCH	Nozzle	Injecteur	Düse
15	75439	00754R0390	2	2	2	2	—	—	—	—	Rondella rame	Washer	Rondelle	Unterlegscheibe
16	71728	00717R0280	2	2	2	2	—	—	—	—	Raccordo	Union	Raccord	Anschlußstück
17	64443	00644R0430	—	—	—	—	2	2	2	2	Iniettore completo STANADYNE	Injector	Injecteur compl.	Einspritzdüse
	64440	00644R0400	—	—	—	—	2	2	2	2	Iniettore completo BOSCH	Injector	Injecteur compl.	Einspritzdüse
18	54089	00540R0890	—	—	—	—	2	2	2	2	Molla iniettore	Spring	Ressort	Feder
19	64445	00644R0450	—	—	—	—	2	2	2	2	Polverizzatore BOSCH	Nozzle	Injecteur	Düse
	64446	00644R0460	—	—	—	—	2	2	2	2	Polverizzatore STANADYNE	Nozzle	Injecteur	Düse
20	75402	00754R0020	—	—	—	—	4	4	4	4	Rondella rame D.8,2x12 sp.1	Washer	Rondelle	Unterlegscheibe
21	71670	0019010290	—	—	—	—	2	2	2	2	Raccordo m.8x1 l.16	Union	Raccord	Anschlußstück
22	35523	00355R0230	2	2	2	2	—	—	—	—	Distanziale	Spacer	Entretoise	Distanzstück
23	43511	00435R0110	2	2	2	2	—	—	—	—	Ghiera	Ring Nut	Embout	Nutmutter
24	54078	00540R0780	2	2	2	2	2	2	2	2	Molla	Spring	Ressort	Feder
25	2871	0028710000	2	2	2	2	2	2	2	2	Raccordo con riempitore	Union	Raccord	Anschlußstück

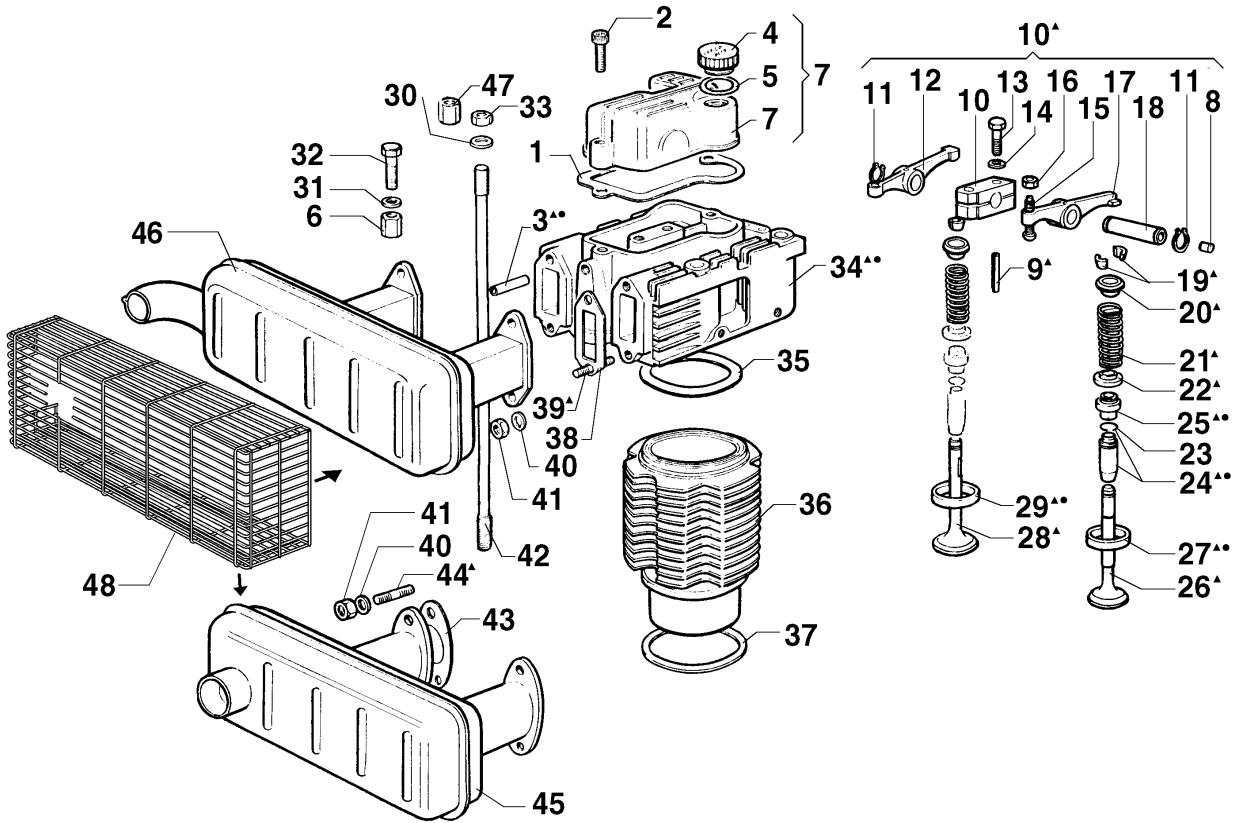

● ■ ▲ Particolari che compongono i kits / Parts included in the kit / Pièces comprises dans les kits / Bausatzteile

Nr. No.	OLD CODE	NEW CODE	RD180	RD200	RD210	RD218	RD220	RD240	RD270	RD278	DENOMINAZIONE - DESCRIPTION - DENOMINATION - BENENNUNG			
			RD181	RD201	RD211	Q.ty	Q.ty	Q.ty	Q.ty	Q.ty	Q.ty	Q.ty		
1	44853	00448R0530	2	2	2	2	2	2	2	2	Guarnizione coperchio bilancieri	Gasket	Joint	Dichtung
2	99230	0097320640	4	4	4	4	4	4	4	4	Vite M.8x30	Capscrew	Vis	Schraube
3	94882	00948R0820	2	2	2	2	2	2	2	2	Tubetto lubrificazione su testa	Pipe	Tuyau	Rohr
4	89421	00894R0210	2	2	2	2	2	2	2	2	Tappo carico olio	Threaded plug	Bouchon fileté	Verschlußschraube
5	57947	00579R0470	2	2	2	2	2	2	2	2	Anello OR D.25.07 sez.2,62	O-ring	Joint torique	O-Ring
6	32625	00326R0250	2	2	2	2	2	2	2	2	Dado testa M.10x1.25 h.30	Nut	Ecrou	Mutter
7	23340	00233R0400	2	2	2	2	2	2	2	2	Coperchio bilancieri	Rocker arm cover	Couver. culbuteurs	Kipphebeldeckel
8	88644	00886R0440	2	2	2	2	2	2	2	2	Tappo a scodellino D.7	Plug	Bouchon	Verschuß
9	85035	00850R0350	2	2	2	2	2	2	2	2	Spina elastica d.5X40	Taper pin	Goupille	Kegelstift
10	10427	00104R0270	2	2	2	2	2	2	2	2	Gruppo bilancieri	Rocker arms	Culbuteurs compl.	Kipphebel
11	04611	0012400110	4	4	4	4	4	4	4	4	Anello seeger esterno e.17	Snap ring	Circlip	Sicherungsring
12	10425	00104R0250	2	2	2	2	2	2	2	2	Bilanciere aspirazione	Inlet rocker arm	Culbuteurs admis.	Einlasskippebel
13	99540	0017700140	4	4	4	4	4	4	4	4	Vite vite M.8x45	Screw	Vis	Schraube
14	77111	00771R0110	4	4	4	4	4	4	4	4	Rondella piana D.8,4x15 sp.1,5	Washer	Rondelle	Unterlegscheibe
15	72603	00726R0030	4	4	4	4	4	4	4	4	Registro bilancieri	Setscrew	Vis réglage	Einstellschraube
16	32307	00323R0070	4	4	4	4	4	4	4	4	Dado M.6 H.6	Nut	Ecrou	Mutter
17	10426	00104R0260	2	2	2	2	2	2	2	2	Bilanciere scarico	Exhaust rocker arm	Culbuteurs échapp.	Auslasskippebel
18	60162	00601R0620	2	2	2	2	2	2	2	2	Perno bilancieri	Rocker arm shaft	Axe culbuteur	Kipphebelzapfen
19	80904	0080570030	8	8	8	8	8	8	8	8	Semicono	Cotter	Semi-cône	Ventilkegelstück
20	61636	00616R0360	4	4	4	4	—	—	—	—	Piattello superiore valvola	Retainer	Coupelle	Federteller
	61638	00616R0380	—	—	—	—	4	4	4	4	Piattello superiore valvola	Retainer	Coupelle	Federteller
21	54077	00540R0770	4	4	4	4	—	—	—	—	Molla valvola	Spring	Ressort	Feder
	54058	00540R0580	—	—	—	—	4	4	4	4	Molla valvola	Spring	Ressort	Feder
22	61635	00616R0350	4	4	4	4	—	—	—	—	Piattello inferiore valvola	Retainer	Coupelle	Federteller
	61611	00616R0110	—	—	—	—	4	4	4	4	Piattello inferiore valvola scar.	Retainer	Coupelle	Federteller
23	05968	00059R0680	4	4	4	4	—	—	—	—	Anello guida valvola	Ring	Bague	Ring
	05901	00059R0010	—	—	—	—	4	4	4	4	Anello fermo guida valvola	Guide ring	Bauge	Ring
24	46477	00464R0770	4	4	4	4	—	—	—	—	Guida valvola	Valve Guide	Guide Soupape	Ventilführung
	46459	00464R0590	4	4	4	4	—	—	—	—	Guida valvola asp/scar + 0.1	Valve Guide	Guide Soupape	Ventilführung
	46476	00464R0760	—	—	—	—	4	4	4	4	Guida valvola	Valve Guide	Guide Soupape	Ventilführung
	46458	00464R0580	—	—	—	—	4	4	4	4	Guida valvola asp/scar + 0.1	Valve guide	Guide soupape	Ventilführung
25	45125	0045350150	4	4	4	4	4	4	4	4	Guarnizione guida valvola opz.	Gasket	Joint	Dichtung
26	96050	00960R0500	2	2	—	2	—	—	—	—	Valvola scarico	Exhaust valve	Soupape échappeme	Auslassventil
	96055	00960R0550	—	—	2	—	—	—	—	—	Valvola scarico	Exhaust valve	Soupape échappeme	Auslassventil
	96057	00960R0570	—	—	—	—	2	2	2	2	Valvola scarico	Exhaust valve	Soupape échapp.	Auslassventil



**TESTA - CYLINDER HEAD  
CULASSE - ZYLINDERKOPF**

CATALOGO RICAMBI SPARE PARTS		
TAVOLA TABLE	<b>7</b>	<b>2</b>
DATA DATE	06/2001	

Nr. No.	OLD CODE	NEW CODE	RD180	RD200	RD210	RD218	RD220	RD240	RD270	RD278	DENOMINAZIONE - DESCRIPTION - DENOMINATION - BENENNUNG			
			RD181 Q.ty	RD201 Q.ty	RD211 Q.ty	Q.ty	Q.ty	Q.ty	Q.ty	Q.ty	Q.ty	Q.ty		
27	05965	00059R0650	2	2	—	2	—	—	—	—	Anello valvola scarico STD	Exhaust valve seat	Siège soupape échapp	Auslassventilsitz
	05974	00059R0740	2	2	—	2	—	—	—	—	Anello scarico +0.2 mm	Exhaust valve seat	Siège soupape échapp	Auslassventilsitz
	05996	00059R0960	—	—	2	—	—	—	—	—	Anello scarico STD	Exhaust valve seat	Siège soupape échapp	Auslassventilsitz
	06007	00060R0070	—	—	2	—	—	—	—	—	Anello scarico +0.5 mm	Exhaust valve seat	Siège soupape échapp	Auslassventilsitz
	06002	00060R0020	—	—	—	—	2	2	2	2	Anello sede valvola asp/scar STD	Ring	Baugue	Ring
	06015	00060R0150	—	—	—	—	2	2	2	2	Anello sede valvola asp/scar +0.5	Ring	Baugue	Ring
28	96049	00960R0490	2	2	—	2	—	—	—	—	Valvola aspirazione	Inlet valve	Soupape admission	Einlassventil
	96056	00960R0560	—	—	2	—	—	—	—	—	Valvola aspirazione	Inlet valve	Soupape admission	Einlassventil
	96057	00960R0570	—	—	—	—	2	2	2	2	Valvola scarico	Exhaust valve	Soupape échapp.	Auslassventil
29	05966	00059R0660	2	2	—	2	—	—	—	—	Anello sede valvola aspiraz. STD	Ring	Bague	Ring
	05975	00059R0750	2	2	—	2	—	—	—	—	Anello aspiraz. +0.2 mm	Ring	Bague	Ring
	05997	00059R0970	—	—	2	—	—	—	—	—	Anello aspiraz. STD	Ring	Bague	Ring
	06008	00060R0080	—	—	2	—	—	—	—	—	Anello aspiraz. +0.5 mm	Ring	Bague	Bague
	06002	00060R0020	—	—	—	—	2	2	2	2	Anello sede valvola asp/scar STD	Ring	Baugue	Ring
	06015	00060R0150	—	—	—	—	2	2	2	2	Anello sede valvola asp/scar +0.5	Ring	Baugue	Ring
30	77116	00771R0160	8	8	8	8	8	8	8	8	Rondella piana D.10.5x22 sp.4	Washer	Rondelle	Unterlegscheibe
31	77114	00771R0140	2	2	2	2	4	4	4	4	Rondella piana d.10.5x21 sp.2	Washer	Rondelle	Unterlegscheibe
32	99571	00995R0710	2	2	2	2	4	4	4	4	Vite vte M.10x1.25x20	Screw	Vis	Schraube
33	32332	00323R0320	4	4	4	4	2	2	2	2	Dado M.10x1.25 H.10	Nut	Ecrou	Mutter
34	2985	0029850000	2	2	—	2	—	—	—	—	Testa motore con guide	Cyl. head with guid.	Culasse avec guide	ZylinderkopfFührung
	A2089	00A20R0890	—	—	2	—	—	—	—	—	Testa motore con guide	Cyl. head with guid.	Culasse avec guide	ZylinderkopfFührung
	A2183	00A21R0830	—	—	—	—	2	2	2	2	Testa motore con guide	Cyl. head with guid.	Culasse avec guide	ZylinderkopfFührung
	2986	0029860000	2	2	—	2	—	—	—	—	Testa motore completa	Complete cyl. head	Culasse complète	ZylinderkopfKomplete
	A2090	00A20R0900	—	—	2	—	—	—	—	—	Testa motore completa	Complete cyl. head	Culasse complète	ZylinderkopfKomplete
	A2184	00A21R0840	—	—	—	—	2	2	2	2	Testa motore completa	Complete cyl. head	Culasse complète	ZylinderkopfKomplete
35	44808	00448R0080	—	—	—	—	2	2	—	—	Guarnizione testa	Cylinder head gasket	Joint culasse	Zylinderkopfdichtung
	45018	00450R0180	2	—	—	—	—	—	—	—	Guarnizione testa	Cyl. head gasket	Joint culasse	Zylinderkopfdichtung
	45045	00450R0450	—	2	—	—	—	—	—	—	Guarnizione testa	Cyl. head gasket	Joint culasse	Zylinderkopfdichtung
	45040	00450R0400	—	—	2	2	—	—	—	—	Guarnizione testa	Cyl. head gasket	Joint culasse	Zylinderkopfdichtung
	44952	00449R0520	—	—	—	—	—	—	2	2	Guarnizione testa	Cylinder head gasket	Joint culasse	Zylinderkopfdichtung
36	20352	00203R0520	2	—	—	—	—	—	—	—	Cilindro d.80	Cylinder	Cylindre	Zylinder
	20365	00203R0650	—	2	—	—	—	—	—	—	Cilindro d.85	Cylinder	Cylindre	Zylinder
	20373	00203R0730	—	—	2	2	—	—	—	—	Cilindro d.90	Cylinder	Cylindre	Zylinder
	20312	00203R0120	—	—	—	—	2	—	—	—	Cilindro d.90	Cylinder	Cylindre	Zylinder
	20313	00203R0130	—	—	—	—	—	2	—	—	Cilindro d.92	Cylinder	Cylindre	Zylinder
	20368	00203R0680	—	—	—	—	—	—	2	2	Cilindro d.95	Cylinder	Cylindre	Zylinder
37	44807	00448R0070	4	4	4	4	4	4	—	—	Guarnizione piano cilindro sp.0.1	Gasket	Joint	Dichtung
	44848	00448R0480	4	4	4	4	4	4	—	—	Guarnizione piano cilindro sp.0.2	Gasket	Joint	Dichtung
	45197	00451R0970	—	—	—	—	—	—	4	4	Guarnizione piano cilindro 0.1mm	Gasket	Joint	Dichtung
	45198	00451R0980	—	—	—	—	—	—	4	4	Guarnizione piano cilindro 0.2mm	Gasket	Joint	Dichtung
38	44851	00448R0510	—	—	—	—	2	2	2	2	Guarnizione collettore scarico	Gasket	Joint	Dichtung
39	67664	00676R0640	—	—	—	—	8	8	8	8	Prigioniero M.8x20 r.20/5/15	Stud	Goujon	Stiftschraube
40	76302	00763R0020	4	4	4	4	4	4	4	4	Rondella grower d.8 rinforzata	Washer	Rondelle	Unterlegscheibe
41	32590	00325R0900	4	4	4	4	4	4	4	4	Dado speciale M.8 ch.12	Nut	Ecrou	Mutter
42	68425	00684R0250	8	8	8	8	—	—	—	—	Prigioniero cilindro	Cylinder stud	Goujon	Stiftschraube
	68411	00684R0110	—	—	—	—	8	8	8	8	Prigioniero cilindro	Cylinder stud	Goujon	Stiftschraube
43	45013	00450R0130	2	2	2	2	—	—	—	—	Guarnizione aspiraz. scarico	Gasket	Joint	Dichtung
44	67670	00676R0700	4	4	4	4	4	4	4	4	Prigioniero M.8x20	Stud	Goujon	Stiftschraube
45	52717	00527R0170	1	1	1	1	—	—	—	—	Marmitta	Muffler	Pot échappement	Auspufftopf
46	52637	00526R0370	—	—	—	—	1	1	1	1	Marmitta	Muffler	Pot échappement	Auspufftopf
47	32563	00325R0630	2	2	2	2	2	2	2	2	Dado alto testa M.10x1.25 h.24	Nut	Ecrou	Mutter
48	68884	00688R0840	1	1	1	1	1	1	1	1	Protezione marmitta	Guard	Protection	Schutz



**FILTRI ARIA - AIR CLEANERS**  
**AIR CLEANERS - LUFTFILTER**

CATALOGO RICAMBI SPARE PARTS		
TAVOLA TABLE	8	1
DATA DATE	06/2001	

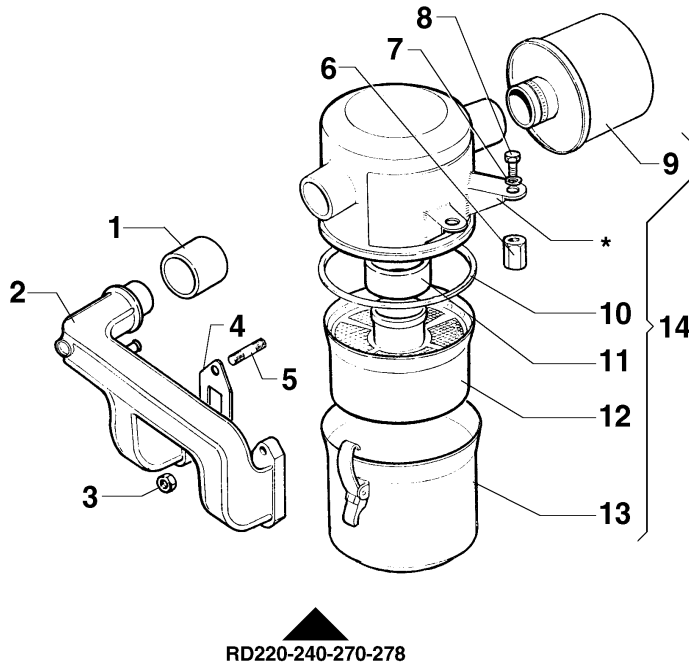

RD220-240-270-278

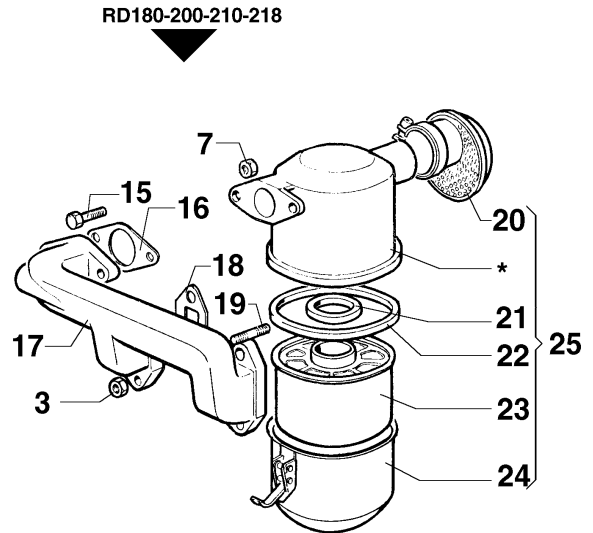

RD180-200-210-218

\* Particolari non forniti sciolti / Parts not to be supplied loose / Pièces qui ne sont pas fournies séparées / Nicht lose gelieferte teile

Nr. No.	OLD CODE	NEW CODE	RD180	RD200	RD210	RD218	RD220	RD240	RD270	RD278	DENOMINAZIONE - DESCRIPTION - DENOMINATION - BENENNUNG			
			RD181	RD201	RD211	Q.ty	Q.ty	Q.ty	Q.ty	Q.ty	Q.ty	Q.ty		
1	51068	00510R0680	—	—	—	—	1	1	1	1	Manicotto filtro aria-collettore	Sheat	Monchon	Hülle
2	15148	00151R0480	1	1	1	1	—	—	—	—	Cappellotto filtro aria	Cap	Capouchon	Schutzkappe
2	21125	00211R0250	—	—	—	—	1	1	1	1	Collettore aspirazione	Intake manifold	Collecteur admiss.	Ansaugsammelrohr
3	32303	00323R0030	4	4	4	4	4	4	4	4	Dado M.8 H.8	Nut	Ecrou	Mutter
4	44852	00448R0520	—	—	—	—	2	2	2	2	Guarnizione collettore aspiraz.	Gasket	Joint	Dichtung
5	67664	00676R0640	—	—	—	—	4	4	4	4	Prigioniero M.8x20 r.20/5/15	Stud	Goujon	Stiftschraube
6	32586	00325R0860	—	—	—	—	2	2	2	2	Dado alto testa M.10x1.25 h.36	Nut	Ecrou	Mutter
7	77114	00771R0140	—	—	—	—	2	2	2	2	Rondella piana d.10.5x21 sp.2	Washer	Rondelle	Unterlegscheibe
8	99571	00995R0710	—	—	—	—	2	2	2	2	Vite vte M.10x1.25x20	Screw	Vis	Schraube
9	67015	00670R0150	—	—	—	—	1	1	1	1	Prefiltro	Prefilter	Préfiltre	Vorfilter
10	57959	00579R0590	—	—	—	—	1	1	1	1	Anello OR	O-ring	Joint torique	O-ring
11	44971	00449R0710	—	—	—	—	1	1	1	1	Anello distanziale	Spacer ring	Bague entretoise	Abstandsring
12	35925	00359R0250	—	—	—	—	1	1	1	1	Elemento filtrante	Filter element	Element filtrant	Filtereinsatz
13	25227	00252R0270	—	—	—	—	1	1	1	1	Coppa olio filtro aria	Oil sump	Carter huile	Ölwanne
14	38837	00388R0370	—	—	—	—	1	1	1	1	Filtro aria con prefiltro	Air cleaner	Filtre air	Luftfilter
15	99302	0017700890	2	2	2	2	—	—	—	—	Vite M.8x30	Capscrew	Vis	Schraube
16	44814	00448R0140	1	1	1	1	—	—	—	—	Guarnizione asp.scar.	Gasket	Joint	Dichtung
17	21138	00211R0380	1	1	1	1	—	—	—	—	Collettore aspirazione	Intake manifold	Collecteur admiss.	Ansaugsammelrohr
18	45013	00450R0130	2	2	2	2	—	—	—	—	Guarnizione aspiraz. scarico	Gasket	Joint	Dichtung
19	67614	00676R0140	4	4	4	4	—	—	—	—	Prigioniero M.8x25 r.16/5/20	Stud	Goujon	Stiftschraube
21	44934	00449R0340	1	1	1	1	—	—	—	—	Guarnizione	Gasket	Joint	Dichtung
22	57941	00579R0410	1	1	1	1	—	—	—	—	OR D.130.2 Sez.5.34	O-ring	Joint torique	O-Ring
23	35926	00359R0260	1	1	1	1	—	—	—	—	Elemento filtrante	Filter element	Element filtrant	Filtereinsatz
24	25229	00252R0290	1	1	1	1	—	—	—	—	Coppa olio	Oil sump	Carter huile	Ölwanne
25	38854	00388R0540	1	1	1	1	—	—	—	—	Filtro aria con cappellotto	Air cleaner	Filtre air	Luftfilter

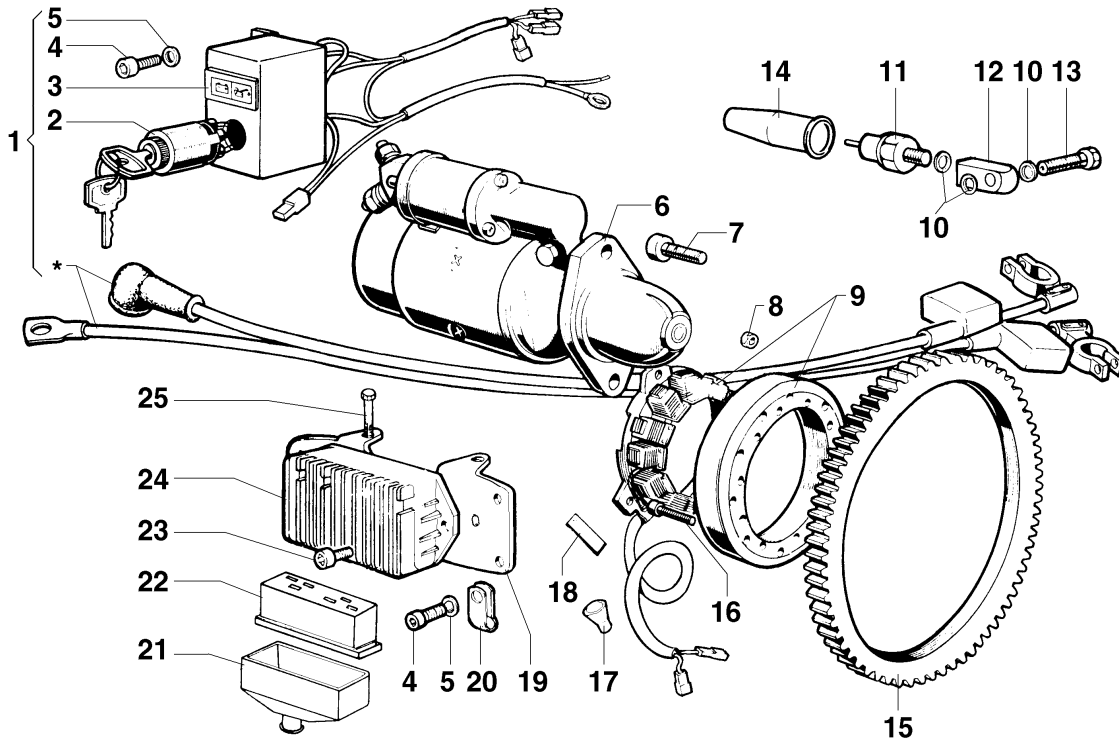

\* Particolari non forniti sciolti / Parts not to be supplied loose / Pièces qui ne sont pas fournies séparées / Nicht lose gelieferte teile

Nr. No.	OLD CODE	NEW CODE	RD180	RD200	RD210	RD218	RD220	RD240	RD270	RD278	DENOMINAZIONE - DESCRIPTION - DENOMINATION - BENENNUNG			
			RD181	RD201	RD211	Q.ty	Q.ty	Q.ty	Q.ty	Q.ty	Q.ty	Q.ty		
1	44419	00444R0190	1	1	1	1	1	1	1	1	Quadro con cavi	Panel w. wires	Cadre compl.	Schaltbrett
2	48404	00484R0040	1	1	1	1	1	1	1	1	Chiave avviamento	Switch	Interrupteur	Schalter
3	48802	00488R0020	1	1	1	1	1	1	1	1	Lampada spia	Lampe	Lampe	Glühbirne
4	99215	0097300080	2	2	2	2	2	2	2	2	Vite	Screw	Vis	Schraube
5	77105	00771R0050	2	2	2	2	2	2	2	2	Rondella piana D.6,4x12,5 sp.1,6	Washer	Rondelle	Unterlegscheibe
6		0058401420	1	1	1	1	—	—	—	—	Motorino avviamento BOSCH	Starting motor	Démarrreur	Anlasser
		0058400890	—	—	—	—	1	1	1	1	Motorino avviamento BOSCH	Starting motor	Démarrreur	Anlasser
7	99233	00992R0330	2	2	2	2	—	—	—	—	Vite M.10x30	Screw	Vis	Schraube
	98949	00989R0490	—	—	—	—	1	1	1	1	Vite	Screw	Vis	Schraube
	99332	0017900200	—	—	—	—	1	1	1	1	Vite	Screw	Vis	Schraube
8	32366	00323R0660	3	3	3	3	3	3	3	3	Dado	Nut	Ecrou	Mutter
9	01441	00014R0410	1	1	1	1	—	—	—	—	Alternatore 280W	Alternator	Alternateur	Drehstrom Gener.
	01409	00014R0090	—	—	—	—	1	1	1	1	Alternatore 210 W	Alternator	Alternateur	Drehstrom gener.
10	75402	00754R0020	3	3	3	3	3	3	3	3	Rondella rame D.8,2x12 sp.1	Washer	Rondelle	Unterlegscheibe
11	67401	00674R0010	1	1	1	1	1	1	1	1	Pressostato	Pressure switch	Mano- contact press	Druckschalter
12	61230	00612R0300	1	1	1	1	1	1	1	1	Piastrina	Safety plate	Arrêtoir	Sicherungsblech
13	71650	00716R0500	1	1	1	1	1	1	1	1	Raccordo sulla testa	Union	Raccord	Anschlußstück
14	15150	0064910130	1	1	1	1	1	1	1	1	Cappello	Cap	Capouchon	Schutzkappe
15	25608	00256R0080	1	1	1	1	—	—	—	—	Corona avviamento	Ring Gear	Couronne Démarrage	Starterkranz
	25621	00256R0210	—	—	—	—	1	1	1	1	Corona avviamento	Ring Gear	Couronne Démarrage	Starterkranz
16	99296	00992R0960	5	5	5	5	5	5	5	5	Vite	Screw	Vis	Schraube
17	15124	00151R0240	1	1	1	1	1	1	1	1	Cappello	Cap	Capouchon	Schutzkappe
18	61376	00613R0760	1	1	1	1	1	1	1	1	Piastrina ferma cavo	Safety plate	Support	Sicherungsblech
19	87571	00875R0710	1	1	1	1	1	1	1	1	Supporto	Support	Support	Lager
20	37512	00375R0120	1	1	1	1	1	1	1	1	Fascetta	Clamp	Collier	Rohrschelle
21	15152	0021450140	1	1	1	1	1	1	1	1	Cappello	Cap	Capouchon	Schutzkappe
22	22203	00222R0030	1	1	1	1	1	1	1	1	Connettore	Connection	Connecteur	Klemmstück
23	99213	0097310920	2	2	2	2	2	2	2	2	Vite M.8x14	Screw	Vis	Schraube
24	73034	00730R0340	1	1	1	1	—	—	—	—	Regolatore Saprisa 12V (alt.280W)	Governor	Régulateur	Regler
	73013	00730R0130	—	—	—	—	1	1	1	1	Regolatore Saprisa 12V (alt.210W)	Governor	Régulateur	Regler
25	99522	0017600440	2	2	2	2	2	2	2	2	Vite	Screw	Vis	Schraube



**DISPOSITIVO ELETTROSTOP PER ARRESTO A DISTANZA - ELECTRO-MAGNET FOR AUTOMATIC SHUT DOWN**  
**DISPOSITIF-ELECTROSTOP ARRET A DISTANCE**  
**ELEKTROSTOP FÜR DAS FERNBEDIENUNG MOTORABSCHALTEN**

CATALOGO RICAMBI SPARE PARTS	
TAVOLA TABLE	<b>10 3</b>
DATA DATE	<b>06/2001</b>

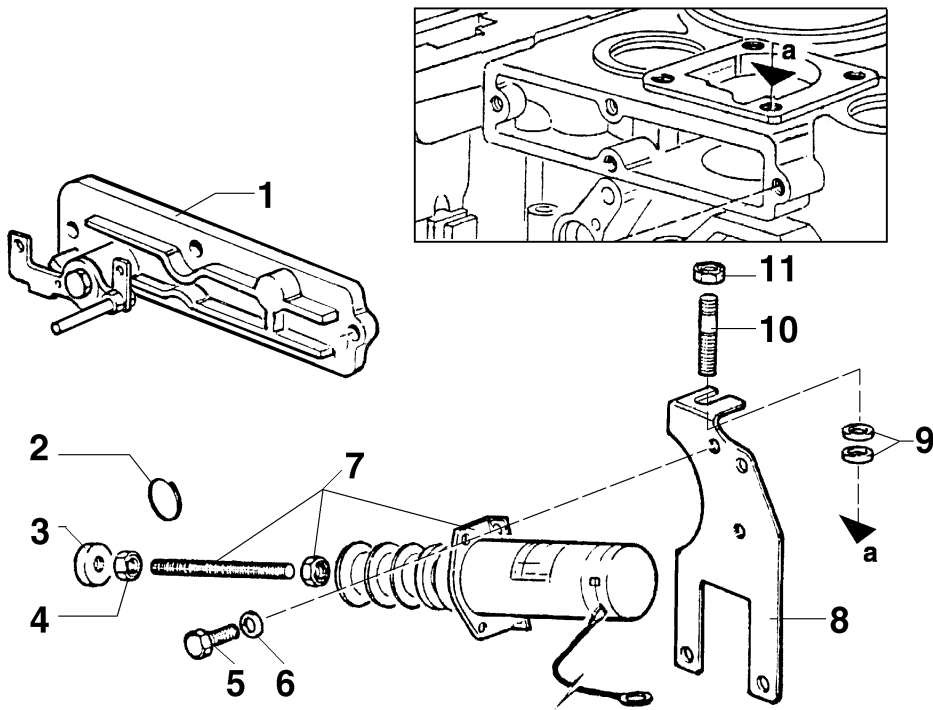

Nr. No.	OLD CODE	NEW CODE	RD180	RD200	RD210	RD218	RD220	RD240	RD270	RD278	DENOMINAZIONE - DESCRIPTION - DENOMINATION - BENENNUNG			
			RD181 Q.ty	RD201 Q.ty	RD211 Q.ty	Q.ty	Q.ty	Q.ty	Q.ty	Q.ty	Q.ty	Q.ty		
1	23313	<b>00233R0130</b>	1	1	1	1	1	1	1	1	Coperchio	Cover	Couvercle	Deckel
2	06011	<b>00060R0110</b>	1	1	1	1	1	1	1	1	Anello di sicurezza	Ring	Bague	Ring
3	32637	<b>00326R0370</b>	1	1	1	1	1	1	1	1	Dado	Nut	Ecrou	Mutter
4	32307	<b>00323R0070</b>	1	1	1	1	1	1	1	1	Dado M.6 H.6	Nut	Ecrou	Mutter
5	99306	<b>0017600050</b>	2	2	2	2	2	2	2	2	Vite TE M.6X16	Capscrew	Vis	Schraube
6	77105	<b>00771R0050</b>	2	2	2	2	2	2	2	2	Rondella piana D.6,4x12,5 sp.1,6	Washer	Rondelle	Unterlegscheibe
7	67446	<b>00674R0460</b>	1	1	1	1	1	1	1	1	Elettrostop	Elettrostop	Elettrostop	Elettrostop
8	87932	<b>00879R0320</b>	1	1	1	1	1	1	1	1	Supporto	Support	Support	Lager
9	77109	<b>00771R0090</b>	2	2	2	2	2	2	2	2	Rondella piana D.8,4x17 sp.1,6	Washer	Rondelle	Unterlegscheibe
10	67712	<b>00677R0120</b>	1	1	1	1	1	1	1	1	Prigioniero M.8X32 r.15/5/27	Stud	Goujon	Stiftschraube
11	32303	<b>00323R0030</b>	1	1	1	1	1	1	1	1	Dado M.8 H.8	Nut	Ecrou	Mutter



PRED. POMPA IDRAULICA GR1 E GR2 SUL CARTER - PRED. FOR HYDRAULIC PUMP GR.1 AND GR.2 ON CRANKCASE  
 PREDISPOSITION POMPE HYDR. GR1 ET GR2 SUR CARTER MOTEUR - KREISELPUMPE ANBAUVORRICHTUNG GR1 GR2

CATALOGO RICAMBI SPARE PARTS		
TAVOLA TABLE	11	1
DATA	06/2001	

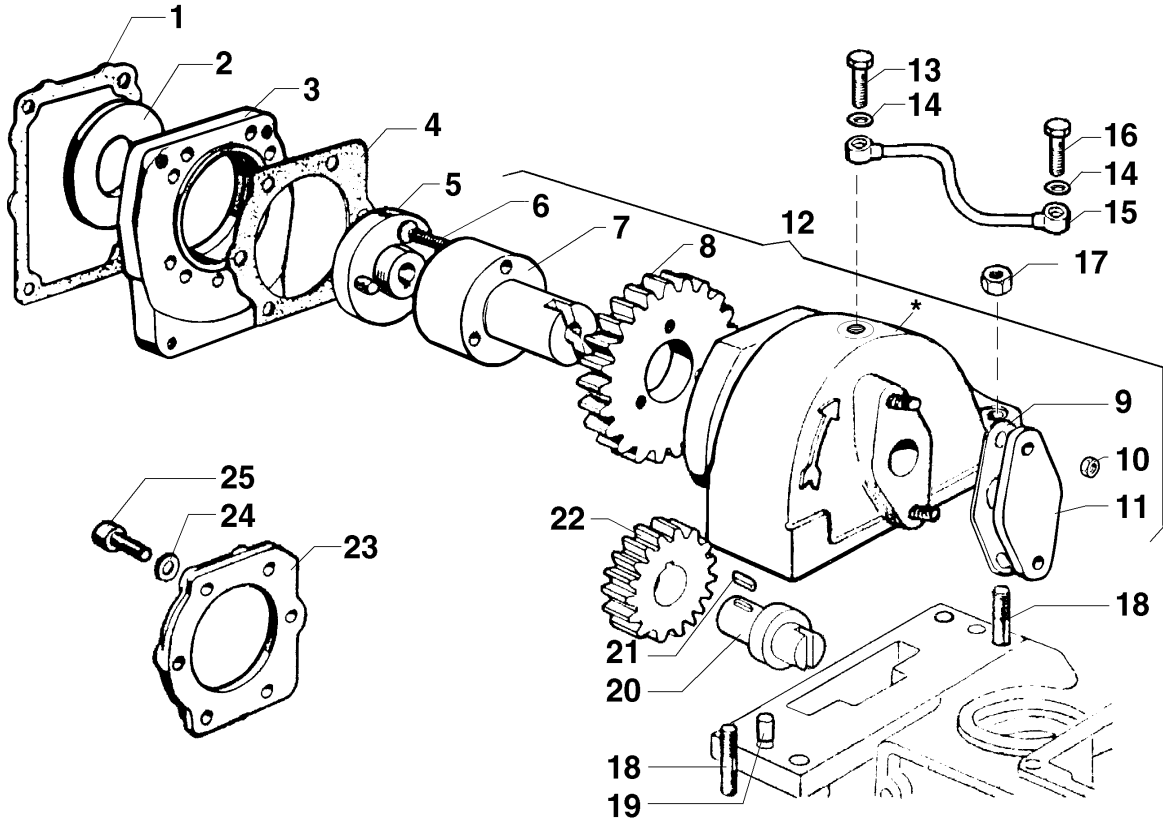

\* Particolari non forniti sciolti / Parts not to be supplied loose / Pièces qui ne sont pas fournies séparées / Nicht lose gelieferte teile

Nr. No.	OLD CODE	NEW CODE	RD180	RD200	RD210	RD218	RD220	RD240	RD270	RD278	DENOMINAZIONE - DESCRIPTION - DENOMINATION - BENENNUNG			
			RD181	RD201	RD211	Q.ty	Q.ty	Q.ty	Q.ty	Q.ty	Q.ty	Q.ty		
1	44801	00448R0010	1	1	1	1	1	1	1	1	Guarnizione pompa idraulica GR.1	Gasket	Joint	Dichtung
	44797	00447R0970	1	1	1	1	1	1	1	1	Guarnizione pompa idraulica GR.2	Gasket	Joint	Dichtung
2	04203	00042R0020	1	1	1	1	1	1	1	1	Anello riduz. per GR.1	Ring	Bague	Ring
	04203	00042R0030	1	1	1	1	1	1	1	1	Anello riduz. per GR.2	Ring	Bague	Ring
3	87448	00874R0480	1	1	1	1	1	1	1	1	Supporto pompa idr. GR.1	Support	Support	Lager
	87446	00874R0460	1	1	1	1	1	1	1	1	Supporto pompa idr. GR.2	Support	Support	Lager
4	44795	00447R0950	6	6	6	6	6	6	6	6	Guarnizione	Gasket	Joint	Dichtung
5	81469	00814R0690	1	1	1	1	1	1	1	1	Semigiunto per GR.1	Haft coupling	Demi-accooup.	Kupplung
	81321	00813R0210	1	1	1	1	1	1	1	1	Semigiunto per GR.2	Haft coupling	Demi-accooup.	Kupplung
6	99734	00997R0340	3	3	3	3	3	3	3	3	Vite vtspei M.5X30	Screw	Vis	Schraube
7	60070	00600R0700	1	1	1	1	1	1	1	1	Perno ingranaggio	Shaft	Axe	Zapfen
8	46855	00468R0550	1	1	1	1	1	1	1	1	Ingranaggio com.pompa idr.	Gear	Engrenage	Zahnrad
9	44899	00448R0990	1	1	1	1	1	1	1	1	Guarnizione	Gasket	Joint	Dichtung
10	32306	00323R0060	1	1	1	1	1	1	1	1	Dado M.5 H.5	Nut	Ecrou	Mutter
11	23195	00231R0950	1	1	1	1	1	1	1	1	Coperchio	Cover	Couvercle	Deckel
12	87780	00877R0800	1	1	1	1	1	1	1	1	Supporto pompa idr. completo	Support	Support	Lager
13	71774	00717R0740	1	1	1	1	1	1	1	1	Raccordo M.8X1X20 ( foro 0,9)	Union	Raccord	Anschlußstück
14	75402	00754R0020	4	4	4	4	4	4	4	4	Rondella rame D.8,2x12 sp.1	Washer	Rondelle	Unterlegscheibe
15	94973	00949R0730	1	1	1	1	1	1	1	1	Tubo lubrificaz. Ingr.pompa idr.	Pipe	Tuyau	Rohr
16	71618	00716R0180	1	1	1	1	1	1	1	1	Raccordo 8x1x30 a due fori	Union	Raccord	Anschlußstück
17	32590	00325R0900	2	2	2	2	2	2	2	2	Dado speciale M.8 ch.12	Nut	Ecrou	Mutter
18	67667	00676R0670	4	4	4	4	4	4	4	4	Prigioniero M.8X32 r.18/12/20	Stud	Goujon	Stiftschraube
19	84110	00841R0100	2	2	2	2	2	2	2	2	Spina cilindrica D.6X16	Shim	Cale	Unterlegscheibe
20	60296	00602R0960	1	1	1	1	1	1	1	1	Perno ingranaggio ozioso	Shaft	Axe	Zapfen
21	49824	00498R0240	1	1	1	1	1	1	1	1	Linguetta 4x4x8	Key	Clavette	Keil
22	47048	00470R0480	1	1	1	1	1	1	1	1	Ingranaggio ozioso	Gear	Engrenage	Zahnrad
23	23126	00231R0260	1	1	1	1	1	1	1	1	Coperchio supporto pompa idr.	Cover	Couvercle	Deckel
24	77105	00771R0050	6	6	6	6	6	6	6	6	Rondella piana D.6,4x12,5 sp.1,6	Washer	Rondelle	Unterlegscheibe
25		0097300120	6	6	6	6	6	6	6	6	Vite M.6 x 20 TCEI	Screw	Vis	Schraube



**RUGGERINI MOTORI**

Via Cav. Del Lavoro A.Lombardini, 2 - 42100 Reggio Emilia - ITALY  
Italia/Domestic Tel. 0522 389359 - Estero/Export Tel. 0522 389360 - Fax 0522 389362  
www.ruggerini.it - E-mail: marketing@ruggerini.it

è un marchio della  
 **LOMBARDINI** s.r.l.

00496R0730 0050 06/01 Descrizioni e illustrazioni non impegnative - Descriptions and characteristics subject to modification - Descriptions et illustrations peuvent être modifiées - Änderungen vorbehalten